

Steam

Bürkert Fluid Control Systems

Christian-Bürkert-Straße 13-17
74653 Ingelfingen
Germany

Tel. +49 (0) 7940/10-0
Fax +49 (0) 7940/10-91 204

info@burkert.com
www.burkert.com

bürkert
FLUID CONTROL SYSTEMS



Content

- 5 _____ Company Profile
- 6 _____ Products and Systems
- 9 _____ Steam Systems
- 12 _____ Boiler House
- 15 _____ Cooking
- 16 _____ Heat Exchangers
- 20 _____ Clean Steam
- 23 _____ Sterilizers and Washers
- 24 _____ Reactions
- 27 _____ Coloring
- 30 _____ Contacts at Bürkert



Our focus on steam derives from a commitment to our customers to work with the physical attributes of the application environments of your world. In this overview you will find examples which allow you to find out more about our core process expertise.

We believe we have intimate knowledge and significant insight into the application environments that traverse the broad spectrum of steam applications. We can collaborate with you in the real physics of steam production, distribution and heat transfer where we can share our experience in complete control loops.

We can assist you in determining the most effective steam control architecture to help you see and assess what is happening in your plant from the control room to the boardroom. Every member of our company listens to you with the aim of fluently presenting you with only the most appropriate solution in your daily application language. The inherent expertise we offer at Bürkert exists to make your life simpler.

Our versatile systems highlight our continuous customer-oriented innovation and are developed to uncomplicate any steam control or monitoring situation, which in turn will save you time. An otherwise unattainable synergy of hardworking valve elements, process controllers and sensors provide a true single source of remarkably attractive systems, as well as peace of mind, process safety and joy of use. In a world where application knowledge, reliability and quality are paramount, Bürkert offers you unlimited modularity to control the invisible.

Welcome to the Fascinating World of Fluid Control Systems.

Measurement and control: When it comes to working with fluids and gases, we are at your side—as a manufacturer of sophisticated products, as a problem-solver with an eye for the big picture, and as a partner offering you reliable advice. Since we started in 1946, we have developed into one of the world's leading suppliers of Fluid Control Systems. At the same time we have kept our status as a family-run business with a foundation of strong basic values to highlight the way we think and act.

What we build on: Experience

We bring together over 60 years of applied knowledge, theoretical expertise and all-round experience in the field of Fluid Control Systems. We at Bürkert have always taken care to ensure that the insights gained in working on innumerable products and projects are passed on, not only among our over 2,100 employees in various locations and divisions, but also from one Bürkert generation to the next. We focus all our curiosity, passion and commitment on one goal: to provide solutions that take your company that essential step forward.

What sets us apart: Closeness

To engineer expert solutions with added value, you need to be close to your customers and their problems—as we are. For us at Bürkert, closeness means personal closeness. We listen to your every word and do everything in our power to devise and implement the best solution for your needs. Closeness also applies in a technical sense. We know exactly what role our products play in your complex processes. Last but not least, we understand closeness in a geographical sense: Our global presence with over 35 branches and seven production sites allows our customers to draw on technological innovations from all over the world.

What drives us forward: Courage

We aim to surpass your expectations. To make it happen, one quality is vital: courage. The courage not just to look forward but to move forward, to challenge conventional wisdom, to do things differently, to tackle problems others think are impossible and to never give up when the going gets tough. We demonstrate this courage time and again. Our wealth of experience is the solid platform on which our courage is based. It allows us to turn courage into creativity, convert off-beat ideas into surprising innovations and put together individual components to create completely new systems that open up unexpected possibilities.





Good from Every Angle: Our Products.

Fluids are fascinating media. It is this very fascination with liquids and gases that drives us to develop ever new devices that can handle them even better. We are one of the few suppliers on the market to cover the complete control loop. Our current product range extends from solenoid valves and pneumatically actuated valves to sensors for conductivity and temperature.

To meet our customers' ever-increasing demands, the people at our four research and development centers constantly work on improving both our individual products and our range as a whole. Products that solve a particular problem perfectly, that offer a true value-added benefit over other products, and that meet specific requirements found in steam environments.

In all aspects of the handling of steam, we have worked continuously to steer the latest specifications, requirements, and to be involved with special interest groups that push the industry towards higher standards and improved value for their customers. We believe we have done the work that allows you to conduct your business with peace of mind. When you specify Bürkert you know you will receive real, traceable, and consistent quality ... quickly.

Innovative, Value-added Solutions Combine the Best of All Worlds.

You can see Bürkert as a supplier who simply provides you with good products. We are happy to fill that role—but what really makes us proud is when you see us as a partner who joins you in getting the job done—however complex. Even if your steam problem seems irresolvable, challenge us.

Put our courage to the test: It's the tough challenges that drive us, moving you and us forward. Whether with an individual component or a groundbreaking new system for the entire process of measurement and control, we are at your side at all times with a seamless range of services, from consulting and engineering, to installation, testing and after-sales service.

We work with engineering consultants, integrators, contractors, original equipment manufacturers, and end users in a spectrum of industries from infection control to textiles. We offer expertise in optimized system solutions for cooking, boiler management, wash down and curing ... in your application language. Speaking a common language eases communication and lays the foundation for your success.

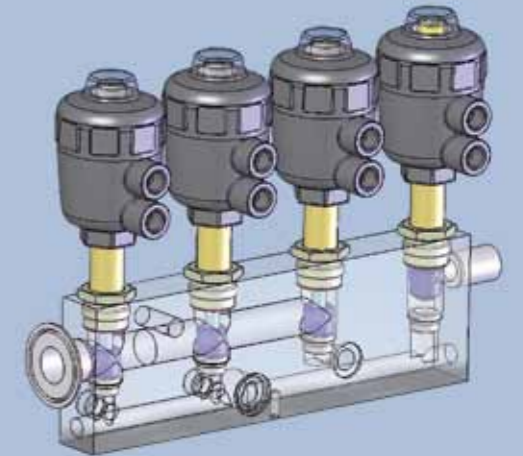
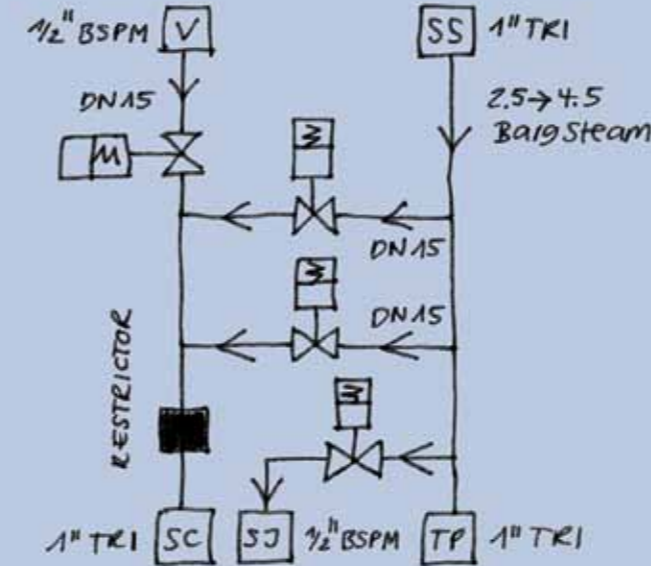

IDEAS & CONSULTING

SIMULATION & DEVELOPMENT

SYSTEM

PROTOTYPE





Stoom, Dampf, Vapeur, Vapor, Para, Atmos, Abur, Vapore, スチーム, 蒸汽..

Steam is an amazing substance. It is the most versatile industrial heating medium. It can transfer large amounts of heat energy at constant temperatures without additional propulsion. It is clean, non-toxic, nonflammable, and comes from an abundant source ... water.

It is used to make paper, food, pharmaceuticals, fuel, chemicals, and power. It sets jams, sterilizes surgical instruments, vulcanizes rubber, corrugates cardboard, shrink wraps meat, caps bottles, dyes yarn, peels potatoes, extinguishes fires, heats chocolate, inflates sterile rubber gloves, washes milk bottles, irons clothes, heats pipes, makes coffee instant, provides domestic hot water, pasteurizes milk and explodes corn to make corn flakes.

Bürkert is therefore connected to your everyday life as we supply the steam industry with fit and forget quality solutions which make these things possible.

We speak the language of steam.



On/off control valve for cooking environment



Typical control component



Wide range of solenoid valves



EXPERIENCE

Take advantage of our Steam experience. Even if the problem seems irresolvable, challenge us, put our courage to the test—it is the tough challenges that drive us, moving you and us forward. We are at your side at all times with a seamless range of services, from heat exchange consulting and engineering through installation and testing all the way to aftersales service—no matter whether it is an individual component or a groundbreaking new system for the entire process of measurement and control.

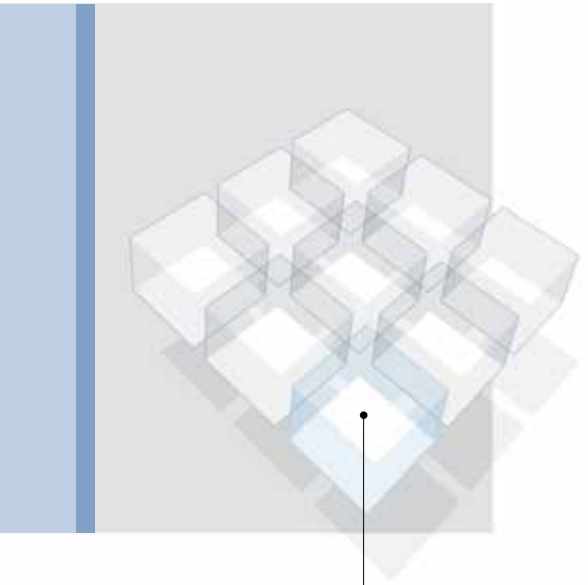

Boiler room peace of mind.

Full Steam Ahead.

As industrial trends demand the use of more automation, Bürkert can be seen as a reliable partner who can improve efficiency while maintaining the integrity and safety of your boiler house.

We are fluent in the language of steam and our consultative approach leads to effective solutions.

We can measure and control total dissolved solids (TDS), steam quality, steam distribution, blow-down, feed-water and chemical dosing to keep your valuable system running during periods of peak demand.

Boiler at the heart of the system.



8620/8619 boiler and water treatment controllers



2000/2712 flanged process control valves



6027 solenoid valves for dosing and sampling





The Taste of Success.

Experience gained over many years working with soups, jams, sauces, chocolate, beers and juices means we can accurately control jacketed kettles, direct steam injection and industrial cookers and steamers to perfection.

Our dedication to innovation means we understand batching and continuous heating processes. Our experience in process loops, communication and integrated PID means we are the smart choice for fluid control systems.

Bürkert steam solenoid valves, air-actuated valves, sensors and controllers can be found in all corners of the world and are backed up by qualified staff in 35 local offices.

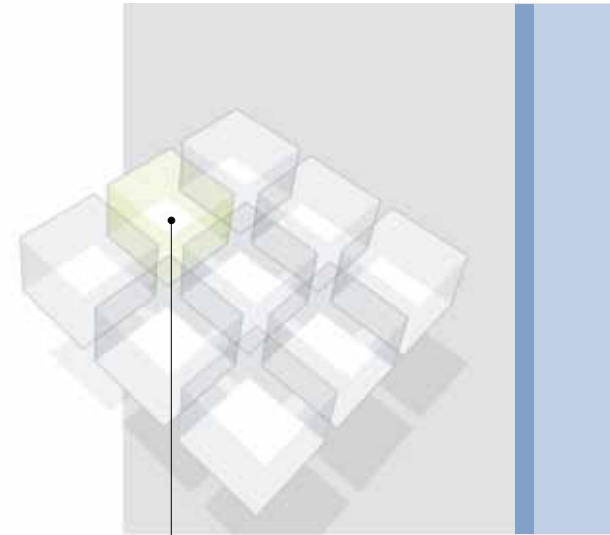

Quality Ingredients.

Precisely controlled jacketed vessels for batching and cooking.



On/off and continuous steam valves



8045 flow transmitter ingredient batching and CIP cycles



1067 valve-mounted PID process controller

Hot Ideas for Precise Control.

Bürkert provides cutting-edge solutions for efficient and accurate heat transfer applications in your world.

Our control solutions offer ease of use, fast reaction times and a reduced footprint for all kinds of heat exchange.

Experience and knowledge transferred over many years means our systems are deployed globally. Our local engineering teams can take your process layout ideas and help you turn them into reality.

Plate and tube are two variations of heat exchange technology.

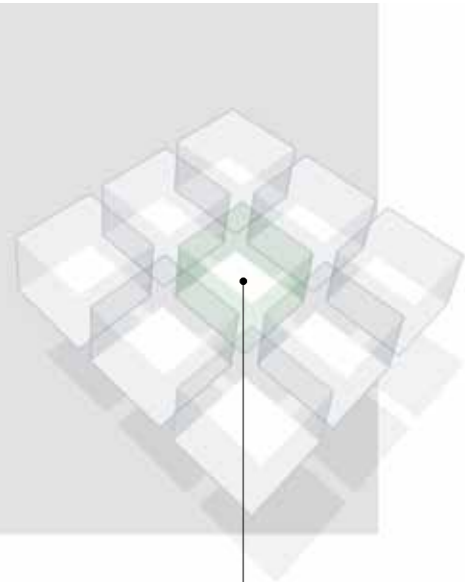

*Hardworking valves
are just the beginning.*



*Diaphragm valves
for product lines*



*8400 temperature
transmitter and display*



2002 rugged 3-way valve





COURAGE

Those who only work toward optimizing things that already exist will eventually reach the limits—technically, financially, or personally. In order to overcome these limits, courage is needed: The courage to be different and trust one's own ideas; the courage to venture into the unknown, searching for new ways to develop products that have never existed before. We have this courage. By pooling and utilizing our competencies across all sectors, you benefit from our cumulative knowledge of Steam.

Pure Innovation.

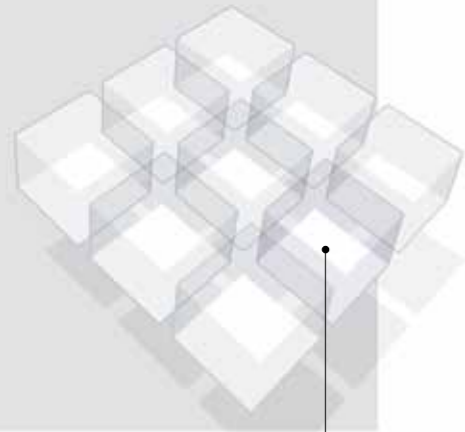

*Pharmaceutical
WFI and clean steam
production.*

Clean steam encompasses a wide spectrum of purity standards from culinary grade in food, beverage and dairy, to pure pyrogen-free steam for the life science industries.

The production and distribution of pure water and clean steam demand exceptionally high standards both in regard to the product and documentation.

Bürkert has built up an indepth understanding of regulatory requirements and our experience is available to you.

Clean steam ... a valuable ingredient.



2034 tandem valve



*8138 sanitary radar
level transmitter*



*ELEMNT weld ends
and clamp*





A Healthier Tomorrow.

Infection protection is a rapidly growing industry where sterility and reliability are crucial.

Our hardworking valve and sensor elements can be found in sterilizers and process autoclaves in laboratories, hospitals, surgeries, food plants, breweries and life science establishments around the globe.

We take time to understand your process requirements, delivering accurate solutions time and again.

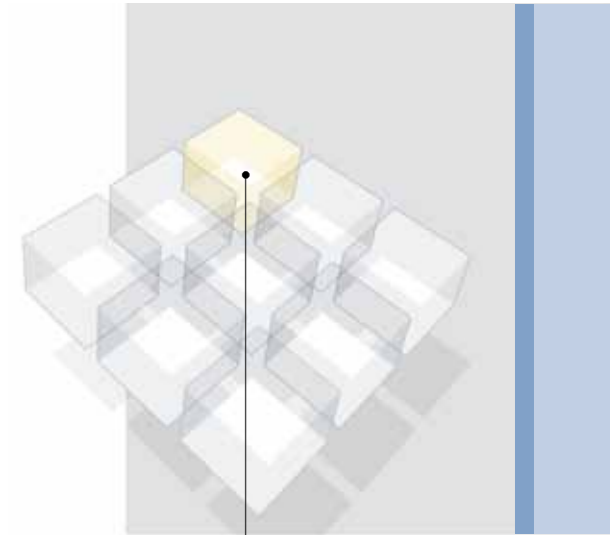

Sterilizers, washers and autoclaves share technology.

Steam works hard to make the world safer.



Specific sterilizer solutions



8323 pressure sensor range with accessories



6240 2/2 way solenoid valve

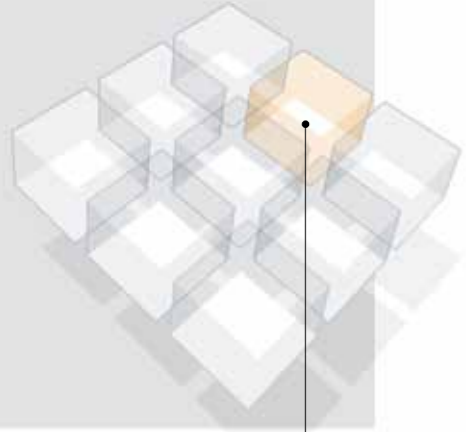

Bürkert: Everyday.

Reaction Time.

Steam is crucial to many reactions which impact on our everyday life—from laundry detergents and cereals to car interiors and cement products.

Whether you are expanding polystyrene, corrugating paper or curing tires, we have previously unattainable synergies of valves, controllers and sensors to uncomplicate your steam world.

With 2,100 people ready to listen ... you can count on Bürkert everyday.

Expanding, curing and forming with steam.



High specification valves for accurate control of reactions



1067 side control positioner



8644 AirLINE process control center





Color Your World.

The name Bürkert is synonymous with components and sub-systems for dyeing technology. We help our global clients produce fast, economic and environmentally-friendly dye-house equipment and networks.

We have energetically pursued the development of high-quality equipment for integration into textile control and management systems. We provide exact saturated steam atmospheres, dye batching systems and ecologically-sound water recycling solutions which enhance textile tensile strength, dyeability, knit quality and handling.

Reproducibility and versatility with a little Bürkert blue.

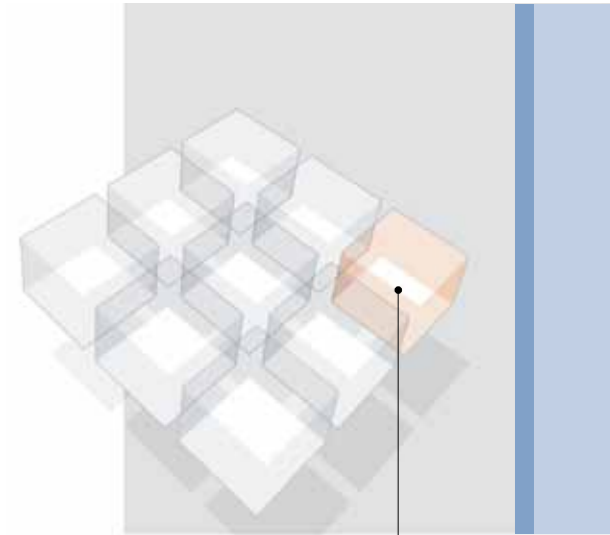

Piece dyeing and finishing.

Dyeing to listen to our customers.



8056 magmeter for dye control



Valves for water and steam



8205/8225 pH and conductivity transmitter



CLOSENESS

To engineer expert solutions with added value we need to be close to you ... our valued customers. We listen to your every word and do everything in our power to devise and implement the best solution for your steam needs. Our global presence with over 35 branches and seven production sites allows our customers to draw on technological innovations from all over the world.

North and South America

Argentina

Bürkert-Contromatic Argentina S.A.
Uruguay 2602, Centro Uruguay Norte,
P.B. Oficina 1
(B1643EKP) Beccar, Pcia. de Buenos Aires
ARGENTINA
Tel: +54 (0)11-5648-6350
Fax: +54 (0)11-5648-6355
E-mail: burkert@burkert.com

Brazil

Bürkert-Contromatic Brasil Ltda.
Rua Américo Brasiliense, 2069
Chacara Santo Antônio
04715-005 São Paulo
SP BRAZIL
Tel: +55 (0)11-2185 11 55
Fax: +55 (0)11-2185 11 65
E-mail: burkert@burkert.br

Canada

Burkert Contromatic Inc.
5002 South Service Road
Burlington, Ontario L7L 5Y7
CANADA
Tel: +1 905-632 30 33
Fax: +1 905-632 38 33
E-mail: sales.ca@burkert.com

USA

BURKERT CONTROMATIC CORP.
2915 Whitehall Park Drive, Suite 100
Charlotte, NC 28273
USA
Tel: +1 704-504 44 40
Fax: +1 704-504 30 47
E-mail: marketing-usa@burkert.com

Europe

Austria

Bürkert-Contromatic G.m.b.H.
Diefenbachgasse 1-3
AT-1150 Wien
Tel: +43 (0)1-894 13 33
Fax: +43 (0)1-894 13 00
E-mail: info@buerkert.at

Belgium

Bürkert Contromatic NV
Wijnegem Zone 1 "De Hoek"
Bijkhoevelaan 3
BE-2110 Wijnegem
Tel: +32 (0)3-325 89 00
Fax: +32 (0)3-325 61 61
E-mail: sales.be@burkert.com

Czech Rep.

Bürkert-Contromatic G.m.b.H. organizacni
slozka
Krenova 35
CZ-602 00 Brno
Tel: +420 543-25 25 05
Fax: +420 543-25 25 06
E-mail: obchod@burkert.cz

Denmark

Bürkert-Contromatic A/S
Hørkær 24
DK-2730 Herlev
Tel: +45 44-50 75 00
Fax: +45 44-50 75 75
E-mail: info.dk@burkert.com

Estonia

Bürkert Oy Eesti
Laki 11 E
EE-12915 Tallinn
Tel: +372 6440 698
Fax: +372 6313 759
E-mail: info@burkert.ee

Finland

Bürkert Oy
Atomitie 5
FI-00370 Helsinki
Tel: +358 (0)207 412 550
Fax: +358 (0)207 412 555
E-mail: sales.fi@burkert.com

France

BURKERT CONTROMATIC SAS
Rue du Giessen
FR-67220 Triembach au Val
Tel: +33 (0)388-58 91 11
Fax: +33 (0)388-57 20 08
E-mail: burkert.france@burkert.com

Germany

Bürkert GmbH & Co. KG
Christian-Bürkert-Straße 13 - 17
DE-74653 Ingelfingen
Tel: +49 (0)7940-10-91 111
Fax: +49 (0)7940-10-91 448
E-mail: info@buerkert.de

Italy

Bürkert Contromatic Italiana S.p.A.
Centro Direzionale „Colombiolo“
Via Roma, 74
IT-20060 Cassina De' Pecchi (Mi)
Tel: +39 02-959 071
Fax: +39 02-959 07 251
E-mail: info@buerkert.it

Norway

Bürkert-Contromatic A/S
Hvamstuppen 17
NO-2013 Skjetten
Tel: +47 63-84 44 10
Fax: +47 63-84 44 55
E-mail: info@burkert.no

Netherlands

Bürkert Contromatic BV
Computerweg 9
NL-3542 DP Utrecht
Tel: +31 (0)346-58 10 10
Fax: +31 (0)346-56 37 17
E-mail: info@burkert.nl

Portugal

Tel: +351 212 898 275
Fax: +351 212 898 276
E-mail: portugal@burkert.com

Poland

Burkert-Contromatic GmbH Oddzial w Polsce
Bernardynska street 14 a
PL-02-904 Warszawa
Tel: +48 (0)22-840 60 10
Fax: +48 (0)22-840 60 11
E-mail: buerkert@buerkert.pl

Spain

Bürkert Contromatic S.A.
Avda. Barcelona, 40
ES-08970 Sant Joan Despi, Barcelona
Tel: +34 93-477 79 80
Fax: +34 93-477 79 81
E-mail: spain@burkert.com

Sweden

Bürkert-Contromatic AB
Skeppsbron 13 B
SE-211 20 Malmö
Tel: +46 (0)40-664 51 00
Fax: +46 (0)40-664 51 01
E-mail: info.se@burkert.com

Switzerland

Bürkert-Contromatic AG Schweiz
Bösch 71
CH-6331 Hünenberg ZG
Tel: +41 (0)41-785 66 66
Fax: +41 (0)41-785 66 33
E-mail: info.ch@buerkert.com

Turkey

Burkert Contromatic Akiskan Kontrol
Sistemleri Ticaret A.S.
1203/8 Sok. No2-E
TR-Yenisehir, Izmir
Tel: +90 (0)232-459 53 95
Fax: +90 (0)232-459 76 94
E-mail: burkert@superonline.com

United Kingdom

Burkert Contromatic Limited
Brimscombe Port Business Park
Brimscombe, Stroud
Glos, GL5 2QQ / UNITED KINGDOM
Tel: +44 (0)1453-73 13 53
Fax: +44 (0)1453-73 13 43
E-mail: sales.uk@burkert.com

Africa

South Africa

Bürkert Contromatic (Proprietary) Limited
233 Albert Amon Road
Millennium Business Park
Meadowdale,
Germiston
(Postal: P.O. Box 26260, East Rand 1462)
SOUTH AFRICA
Tel: +27 (0)11-574 60 00
Fax: +27 (0)11-454 14 77
E-mail: sales.za@burkert.com

Asia Pacific

Australia

BURKERT CONTROMATIC AUSTRALIA
PTY. LIMITED
15 Columbia Way, Norwest Business Park
Baulkham Hills, NSW 2153, AUSTRALIA
Tel: +61 2 8853 6353
Fax: +61 2 8853 6363
E-mail: sales.au@burkert.com

Victoria

BURKERT CONTROMATIC AUSTRALIA
PTY. LIMITED
Unit 11/26-30 Howleys Road
Notting Hill Victoria 3168
Tel: 1300 888 868
Fax: 1300 888 076

Queensland

BURKERT CONTROMATIC AUSTRALIA
PTY. LIMITED
Unit 4/43 Sandgate Road
Albion Queensland 4010
Tel: 1300 888 868
Fax: 1300 888 076

Western Australia

BURKERT CONTROMATIC AUSTRALIA
PTY. LIMITED
Unit 8, 1st Floor, 85 Reid Promenade
Joondalup WA 6027
Tel: 1300 888 868
Fax: 1300 888 076

China

Burkert Contromatic (Shanghai), Co., Ltd.
166 Min Dong Road, Cao Road Town,
Pudong New Area
Henglu Modern Industrial Park Block 6
2nd Floor
Shanghai 201209, P.R. CHINA
Tel: +86 21-5863 99 90
Fax: +86 21-5863 99 68
E-mail: info.chn@burkert.com

Beijing

Burkert Contromatic (Shanghai), Co., Ltd.
Room A 1708, Luowa Building, No.203
Er Qu Lizezhongyuan, Wangjing,
Chaoyang District
Beijing P.R. China, 100102
Tel: +86 10 64399783, 64399793
Fax: +86 10 64399612

Chengdu

Burkert Contromatic (Shanghai), Co., Ltd.
Room 603-604, Fuji Building
26 Dongfeng Road, Shudu Dadao
Chengdu P.R. China, 610061
Tel: +86 28 8443 9064
Fax: +86 28 8445 1341

Guangzhou

Burkert Contromatic (Shanghai), Co., Ltd.
Room 1502, Tower 4, Dong Jun Plaza
828 - 836 Dong Feng Road East
Guangzhou P.R. China, 510080
Tel: +86 20 8769 8379, 8767 8703
Fax: +86 20 87671131

Shanghai

Burkert Contromatic (Shanghai), Co., Ltd.
Room 501/502 Xin Gai Nian Mansion
No.39 Wu Zhong Road
Shanghai P.R. China, 200233
Tel: +86 21 6486 5110
Fax: +86 21 6487 4815

Suzhou

Burkert Contromatic (Shanghai), Co., Ltd.
Unit A5, Suhong Square
No.81 Suhong West Road
SIP Suzhou P.R. China, 215021
Tel: +86 512 6265 9881
Fax: +86 512 6265 9882

Hong Kong

Burkert Contromatic (China/HK) Limited
Unit K, 9/Floor, Kwai Shun Industrial Centre
No. 51-63 Container Port Road
Kwai Chung, N.T., HONG KONG
Tel: +852 248 012 02
Fax: +852 241 819 45
E-mail: info.hkg@burkert.com

India

Burkert Contromatic PVT Ltd
Apex Towers, 1st Floor, No. 54 II Main Rd
RA Puram
Chennai 600 028, INDIA
Tel: +91 (0)44-4230 3456
Fax: +91 (0)44-4230 3232
E-mail: sales.in@burkert.com

Japan

Burkert Ltd.
Imasu moto asakusa-building
4-9-14 Moto Asakusa, Taito-ku
Tokyo 111-0041, JAPAN
Tel: +81 (0)3-5827-0066
Fax: +81 (0)3-5827-0067
E-mail: info.jpn@burkert.com

Osaka

Burkert Ltd.
2-8-8-1103 Higashi Nakajima,
Higashi-Yodogawa-ku
Osaka 533-0033, JAPAN
Tel: +81 (0)6-6320-0880
Fax: +81 (0)6-6320-0881

Korea

Burkert Contromatic Korea Co., Ltd.
C-401, Micro Office Bldg. 554-2
Gasan-Dong, Keumcheon-Gu
Seoul 153-803, KOREA
Tel: +82 (0)2-3462 5592
Fax: +82 (0)2-3462 5594
E-mail: info.kor@burkert.com

Malaysia

BURKERT CONTROMATIC SINGAPORE
PTE LTD
2F-1, Tingkat Kenari 6
Sungai Ara
11960 Penang, MALAYSIA
Tel: +60 (0)4-643 5008
Fax: +60 (0)4-643 7010
E-mail: info.sin@burkert.com

New Zealand

BURKERT CONTROMATIC NEW ZEALAND
LIMITED
44 Rennie Drive
Airport Oaks, Auckland 2022
NEW ZEALAND
Tel: +64 (0)9-256 77 37
Fax: +64 (0)9-256 77 47
E-mail: sales.nz@burkert.com

Philippines

BURKERT CONTROMATIC PHILIPPINES, INC.
8467 West Service Road, Km. 14, Sunvalley
South Superhighway, Parañaque City, 1700
Metro Manila, PHILIPPINES
Tel: +63 (0)2-7766071 / 7764384
Fax: +63 (0)2-776 43 82
E-mail: info.rp@burkert.com

Singapore

BURKERT CONTROMATIC SINGAPORE
PTE LTD
51 Ubi Avenue 1, #03-14
Paya Ubi Industrial Park
Singapore 408933, SINGAPORE
Tel: +65 6844 2233
Fax: +65 6844 3532
E-mail: info.sin@burkert.com

Taiwan

Burkert Contromatic Taiwan Ltd.
9 F, No. 32, Chenggong Road, Sec. 1,
Nangang District
Taipei
TAIWAN 115, R.O.C.
Tel: +886 (0)2-2653 7868
Fax: +886 (0)2-2653 7968
E-mail: info.rc@burkert.com

Credits:

© Christian Bürkert GmbH & Co. KG

Concept and realization:

WOLF, Berlin

Photography: Münch Lichtbilderei Stuttgart;

Studio Flamisch, Düsseldorf;

All people shown are employees at Bürkert

or employees of Bürkert's clients.

Special thanks to our clients for supporting

our photo shootings.