

**bürkert**  
FLUID CONTROL SYSTEMS

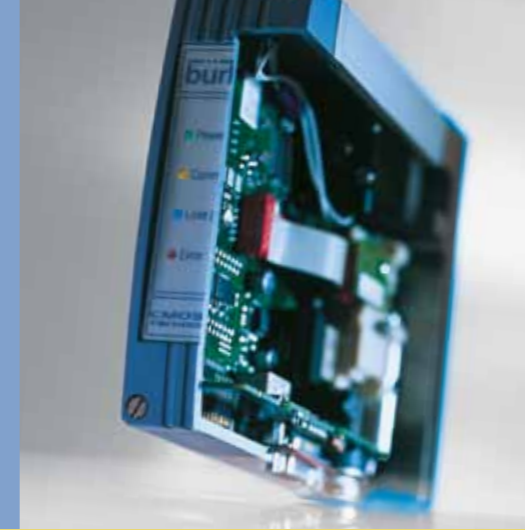

**bürkert**  
FLUID CONTROL SYSTEMS

# Product Overview Mass Flow Controllers for Gases

**Bürkert Fluid Control Systems**  
Christian-Bürkert-Straße 13-17  
74653 Ingelfingen  
Germany  
Tel. +49 (0) 7940/10-0  
Fax +49 (0) 7940/10-91 204  
info@burkert.com  
www.burkert.com

01 SOLENOID VALVES

02 PROCESS VALVES

03 PNEUMATICS

04 SENSORS

05 MICROFLUIDICS

06

07 SOLENOID CONTROL VALVES

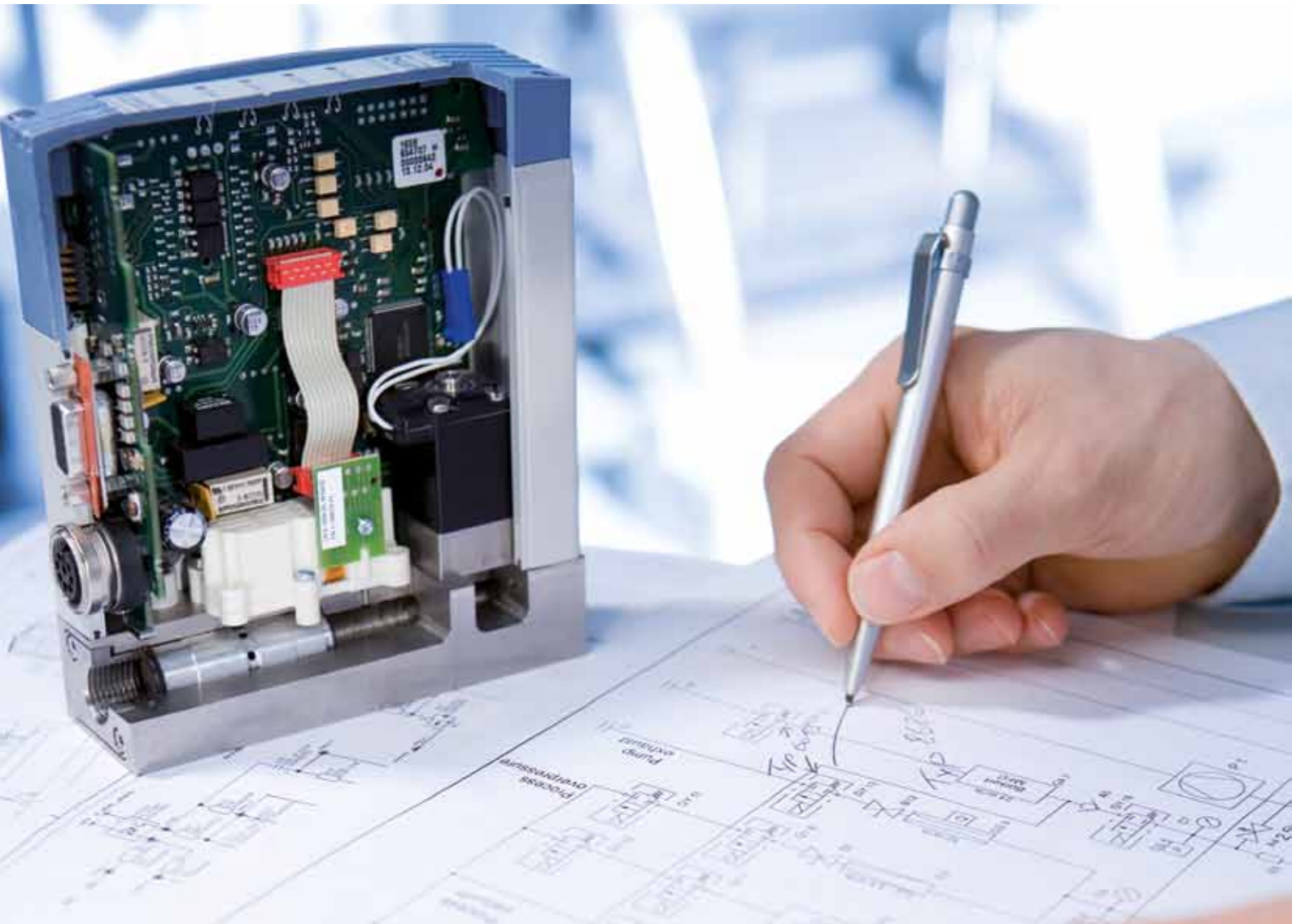

## Content

- 3 Introduction
- 4 Fascination Bürkert
- 6 Product Overview
- 8 Measuring Principle
- 9 Mass Flow Controllers – Setup and Functioning
- 20 Typical Applications
- 22 System Solutions
- 24 Appendix
- 26 Contacts at Bürkert

## Introduction

In industry, when the term “gas” is spoken about in all the languages of Europe, almost everybody means the same thing. What is less known is that the word’s origin is rooted in the Greek word for “chaos”. Coincidence? Probably not! Gases are peculiar. They are volatile, sometimes reactive, and always expansive. This means that gases have very special handling requirements.

Process gases are indispensable in industrial manufacturing. From coating and hardening surfaces, right through to the fermentation processes used in the pharmaceutical world. Inert gases are used for example to protect packaged foodstuffs against the effect of atmospheric oxygen and in metal processing to prevent the oxidation of welds. Reactive gases on the other hand are used in industrial applications to have a specific influence on selected processes, and also in the research and development of new products. Whatever the application, it is all down to precise regulation, constant control and accurate metering of the gas media, ensuring a consistent and reproducible result, whilst maintaining process security and limiting costs.

And nobody knows this better than Bürkert – because we have been successfully measuring, controlling and regulating fluids for more than 60 years. We cover the entire process loop with an impressive range of product diversity. We have always been particularly focused on the flow of gaseous substances, and as a result of our passion, numerous products have been materialised. Bürkert’s Mass Flow Meters (MFM) and Mass Flow Controllers (MFC) rank among the most sought after components in the business. With a well established position in various processes all over the world, they set the standard in the measurement and control of mass flow rates.

Reproducible accuracy and precision, with a coherent price-performance ratio – these are the exceptional characteristics of Bürkert’s thermal MFMs/MFCs. Our mechatronic devices unite the functionality of several components at once, in an efficient compact structure with no moving components in the gas flow. Compactness and device intelligence make gas handling so much easier.

Form your own image of the efficiency of Bürkert’s MFMs/MFCs. This brochure will get you started with its technical descriptions and a detailed product overview.

# Welcome to the Fascinating World of Fluid Control Systems

Measurement and control: When it comes to working with liquids and gases, we are at your side – as a manufacturer of sophisticated products, as a problem-solver with an eye for the big picture, and as a partner offering you reliable advice. Since we started in 1946, we have developed into one of the world's leading suppliers of Fluid Control Systems. At the same time we have kept our status as a family-owned business with a foundation of strong basic values to highlight the way we think and act.

## EXPERIENCE

There are things which are not inherently yours. You have to gather them bit by bit. You receive them from others. And you constantly have to acquire them anew. That is what makes them so valuable. Experience is one of those things. For instance, because of our many years of experience with metering and controlling of gases, we can provide our extensive services to you – from consulting, development, and 3D CAD simulating to testing and after-sales service. Whether individual product solutions or a pioneering new system for the entire control process: Benefit from our experience!

## COURAGE

Those who only work toward optimising things that already exist will eventually reach the limits – technically, financially, or personally. In order to overcome these limits, courage is needed: the courage to be different and trust one's own ideas; the courage to venture into the unknown, searching for new ways to develop products that have never existed before. We have this courage. By pooling and utilising our competencies across all sectors, you benefit from our cumulative knowledge in Gas Handling applications – whether it is plasma gas control or hydrogen in fuel cell technology.

## CLOSENESS

There are things we simply take for granted. Only when they are gone, do we realise how important these things really were. This applies in particular to closeness. Without closeness, it is very difficult to build relationships and a good understanding of one another. As an established medium-sized company, we know that. And that is why we are always there for you. Working with you, we develop the best possible solutions for your projects in the area of Gas Handling. Our global presence in 35 locations enables us to press ahead with technical innovations for our customers around the world.

# Bürkert Product Program

We are one of the few suppliers on the market to cover the complete control loop. Our current product range extends from solenoid valves through process and analytical valves to pneumatic actuators and sensors.



*Bürkert offers a remarkable range of servo-assisted and direct acting solenoid valves. Read more about them in this brochure.*

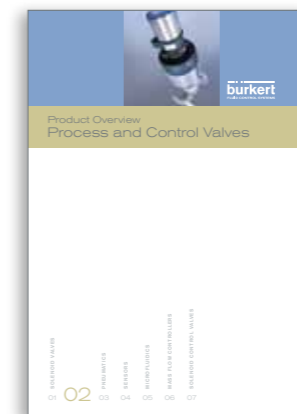

*Bürkert offers unlimited modularity for process control with angle-seat, globe and diaphragm valves in the widest range of configurations.*



*Here you can find our product range of pneumatic valves, valve units and automation systems as well as information on our control cabinet building.*



*Here you can find our sensors, transmitters and controllers for measuring and controlling flow, temperature, pressure, level, pH/ORP and conductivity.*



*The brochure contains an overview of Bürkert miniature valves and micro pumps, which allow for precise and safe handling of small volumes of liquids.*









*This brochure provides technical background information as well as a detailed product overview for the mass flow controller and meter product range.*



*This brochure presents our solenoid control valves including their respective features, functions and typical applications.*



# Product Overview

						
Type	8626 (MFC) / 8006 (MFM)	8710 (MFC) / 8700 (MFM)	8715 (MFC) / 8705 (MFM)	8711 (MFC) / 8701 (MFM)	8712 (MFC) / 8702 (MFM)	8713 (MFC) / 8703 (MFM)
Full scale ranges (273,15 K, 1013,25 mbar)	20 - 1500 I <sub>N</sub> / min (N <sub>2</sub> )	0.005 - 10 I <sub>N</sub> / min (N <sub>2</sub> )		0,01 - 80 I <sub>N</sub> / min (N <sub>2</sub> )		
Sensor technology	Inline Sensor	Capillary Sensor		CMOS Sensor		
Body material	Stainless steel, aluminium	Stainless steel		Stainless steel, aluminium	Stainless steel	Stainless steel, aluminium
Pressure / bar	10	10		10		
Turn-down ratio	1:50	1:50		1:50		
Accuracy	± 1.5% o. R. ± 0.3% of F. S.	± 1.5% o. R. ± 0.3% of F. S.		± 0.8% o. R. ± 0.3% of F. S.		
Settling time	< 500 ms	< 3000 ms		< 300 ms		
Repeatability	± 0.1% of F. S.	± 0.1% of F. S.		± 0.1% of F. S.		
Protection class	IP65	IP40		IP40	IP65	IP40
Communication	Standard signal, RS-232 or RS-422, Profibus DP, DeviceNet, CANopen, Modbus	Standard signal, RS-232 or RS-422, Profibus DP, DeviceNet, CANopen, Modbus	RS232 or RS-422, Modbus	Standard signal, RS-232 or RS-422, Profibus DP, DeviceNet, CANopen, Modbus	Standard signal, RS-232 or RS-422, Profibus DP, DeviceNet, CANopen, Modbus	RS-232 or RS-422, Modbus
Special features	Sensor in contact with medium	Sensor not in contact with medium		Sensor in contact with medium		
	Low pressure drop	Low pressure drop		Low pressure drop		
	No flow conditioning required at inlet or outlet necessary	No flow conditioning required at inlet or outlet necessary		No flow conditioning required at inlet or outlet necessary		
	Neutral gases	Aggressive, toxic gases		Neutral gases		
	Real gas calibration	Real gas calibration or conversion factor		Real gas calibration; conversion factors for some gases possible		
	Leak tightness (outside) down to 10 <sup>-6</sup> mbar I <sub>He</sub> /s	Leak tightness (outside) down to 10 <sup>-9</sup> mbar I <sub>He</sub> /s		Leak tightness (outside) down to 10 <sup>-6</sup> mbar I <sub>He</sub> /s		
Less sensitive to humidity and particles			Less sensitive to humidity and particles			

## The Measuring Principle of Thermal Mass Flow

The physical law is well known – heat always flows towards lower temperatures. So if a body has a higher temperature than its environment, it will give off its heat energy to the neighbouring mass. So our thermal/calorimetric measurement technique utilises this principle, i. e. heat conduction and transportation in gases.

The thermal flow sensors for determining the mass flow rate of gases essentially consist of a heating element and temperature sensors, which can be installed both in and outside the gas flow channel. The heating element heats the gas flowing through, and the temperature sensors detect the dissipated heat volume.

The respective dissipated heat energy is a function of the current mass flow. The mass flow literally defines the weight of the flowing medium, more specifically – this is the weight of the gas that flows through the device in a specific time unit. This is usually given in kg/h, g/s or mol/s. In contrast to the mass flow, the volume flow defines the volume of the gas (measured in m<sup>3</sup>/h, l/min or ml/s) that flows through the device in a specific time unit. If you measure the gas volume, you must know additional values such as temperature and pressure so that you can make comparisons. So there are good reasons for measuring the mass flow and not its volume flow – because gases are compressible. Depending on its pressure and temperature, both the density and therefore its volume will change. In many applications mass flow measurements therefore are more relevant than volume flow measurements.

MFMs/MFCs are ideal for application areas where high precision and reproducibility are required – such as in burner technology, coating systems and fuel cell applications. In addition it is possible to use MFMs/MFCs where the use of volume flow units are standard. Why? Because if we know the standard density, we can calculate the standard volume flow directly from the mass flow value. The rate of the volume flow then refers to the standardised condition for comparability reasons (in acc. with DIN 1343, see “Appendix” on page 24).

The MFMs/MFCs presented in the following pages can be calibrated for both mass flow and volume flow (see “Calibration” on page 16).

## Mass Flow Controllers – Setup and Functioning

The 8626, 8710, 8711, 8712, 8713 and 8715 type Mass Flow Controllers are compact devices that control the mass flow of gases. They control a preset flow rate reference value – regardless of disturbance variables such as pressure fluctuations or temporary occurring flow resistances, e. g. as a result of filter dirt. MFCs consist of the following components: flow sensor, electronics (with signal processing, regulation and valve control functions) and a solenoid control valve as an actuator. The reference value setting is made electrically via analogue signal or fieldbus. The actual value measured by the sensor is compared in the controller with the reference value. The controller gives a pulse-width modulated voltage signal to the actuator as a correcting variable and varies it according to the registered control deviation. The actual value is also transmitted externally via an analogue signal or fieldbus. It is therefore provided to the user for controlling and analysing. With its easy installation, the compact structure of the Mass Flow Controller ensures the convenient operation of a complete (closed) control loop. Additional work and costs, e. g. wiring and harmonising individual components, incorporating pipe lengths (inlet/outlet pipe for flow conditioning), are ruled out.

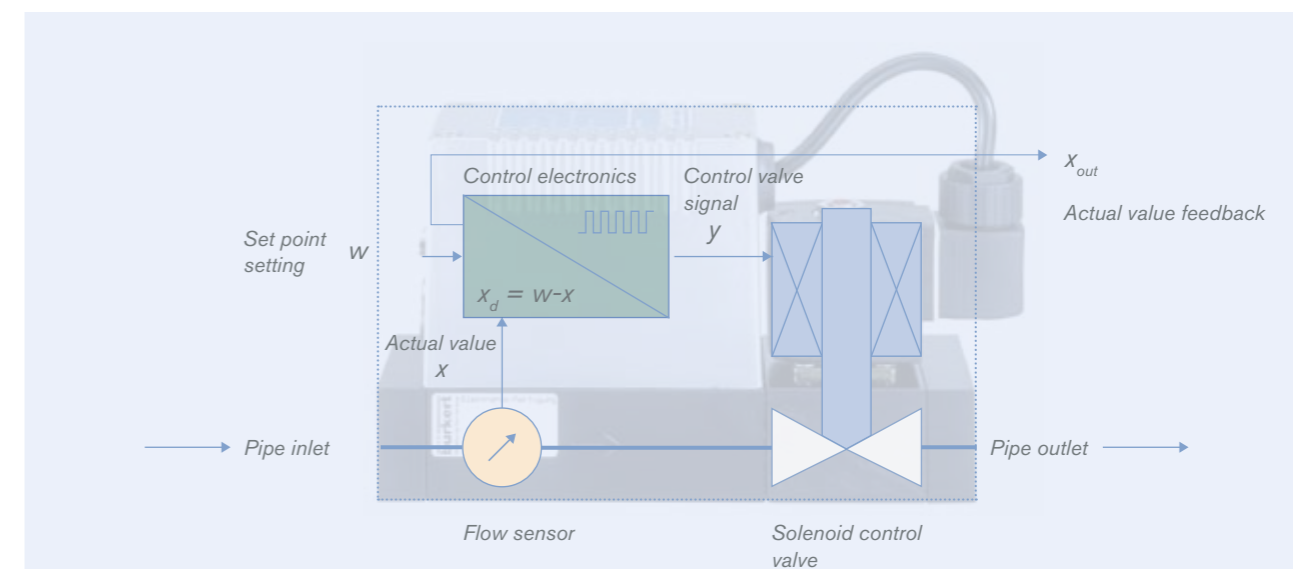

Fig. 1: Basic principle closed control loop

## Inline Sensor

Types 8626/8006

The Inline sensor works in the CTA operating mode (Constant Temperature Anemometer), whereby an electrical heating resistance ( $R_s$ ) and a measurement resistance ( $R_T$ ) are regulated at a constant temperature difference. Both resistances are directly placed in the flow channel; three more resistances are outside. Together they are all connected into a measurement bridge. The first resistance in the gas flow ( $R_T$ ) measures the fluid temperature. The second, low ohmic resistance ( $R_s$ ) is constantly heated just enough so that a fixed preset overtemperature is maintained for the fluid temperature (measured with  $R_T$ ). The heat current required for this is used as the measurement for the gas flowing through the channel. Appropriate flow conditioning in the MFC ensures that the mass flow can be very precisely derived. Because of the arrangement of the  $R_s$  and  $R_T$  resistances directly in the flow channel, the devices have exceptional characteristics, with response times of just a few hundred milliseconds with set point or actual value changes. The sensor arrangement ensures low contamination susceptibility.

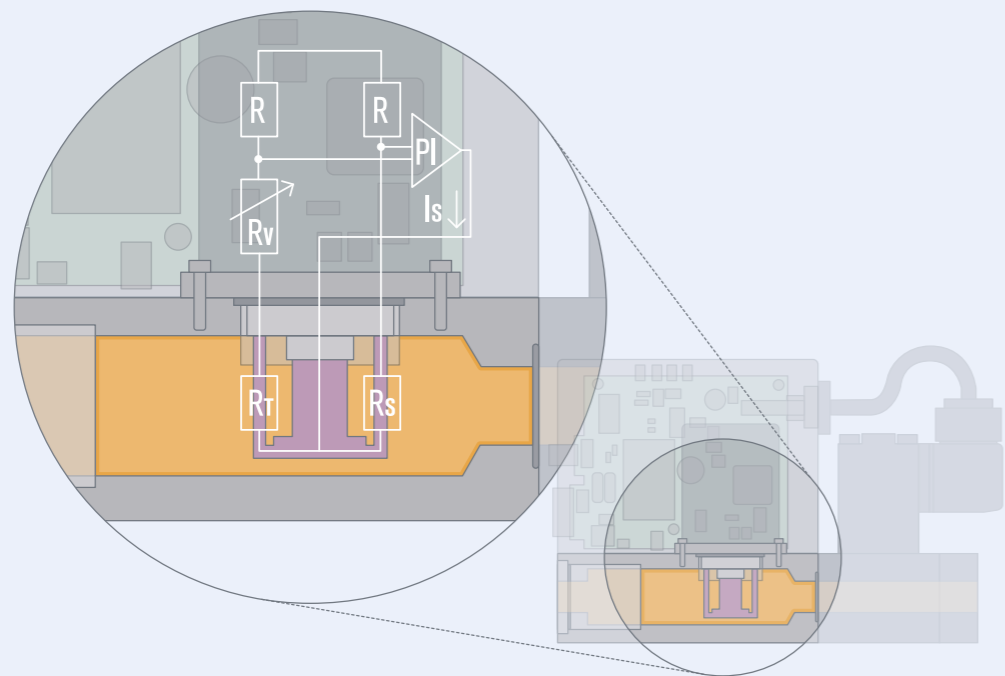

Fig. 2: Functional schematic of Inline sensor

## CMOS Sensor

Types 8711/8701, 8712/8702, 8713/8703

In contrast to the INLINE sensor, with which the mass flow in the main channel is measured, the CMOS sensor determines the values directly in a secondary channel. In detail: A laminar flow element brought into the main channel ensures the necessary pressure drop. This causes a small part of the total flow rate to be diverted into a parallel secondary channel. A silicon chip with a membrane is fitted to the wall of the flow channel for sensing the flow rate. This membrane includes (in CMOSens® technology) a heating resistance and two symmetrical temperature sensors – upstream and downstream. If the heating resistance is now held at a constant temperature, the differential voltage of the temperature sensors applies as the measurement for mass flow rate of the gas flowing over the chip in the flow channel. The low thermal mass of the temperature sensors and their direct contact with the flow have specific advantages including extremely quick response to flow rate changes. The MFC can control set point or actual value changes within 100 ms and it maintains its high sensitivity, even with the smallest flow rates.

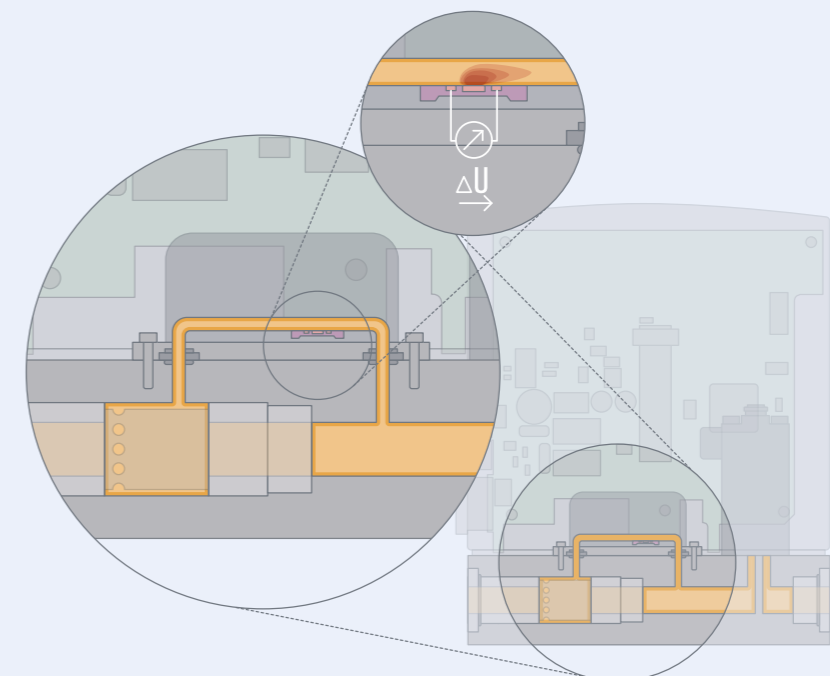

Fig. 3: Functional schematic of CMOS sensor

## Capillary Sensor

Types 8710/8700, 8715/8705

As with the CMOS sensor, a laminar flow element also causes a pressure drop in the main channel with the capillary sensor. A part of the total flow rate flows through a parallel running secondary channel. The decisive differences: the capillary sensor has no direct contact with the medium. The stainless steel capillary is surrounded by two temperature-dependent resistances, which form the half-bridge of a Wheatstone bridge circuit. If gas now flows through the capillary, its gas flow carries heat in the flow direction from  $R_1$  to  $R_2$ . The  $R_1$  resistance value falls; while the value of  $R_2$  increases. If the bridge circuit is fed with constant current, its outlet voltage changes proportionately to the resistance difference. The measuring range then shows a linear dependency between the outlet voltage and mass flow rate of the gas flowing through. This linear dependency even enables the use of gases that the sensor is not calibrated for. The flow rate value is adjusted accordingly to the current medium using a conversion factor. The resulting simplified calibration and the correct material selection for the gas ensures the capillary sensor's suitability for the use with aggressive gases.

The measurement dynamic depends on the wall properties of the stainless steel capillary. It acts to a certain degree as a thermal barrier. The capillary sensor achieves response times of just a few seconds. This is sufficient for many applications with aggressive or toxic gases.

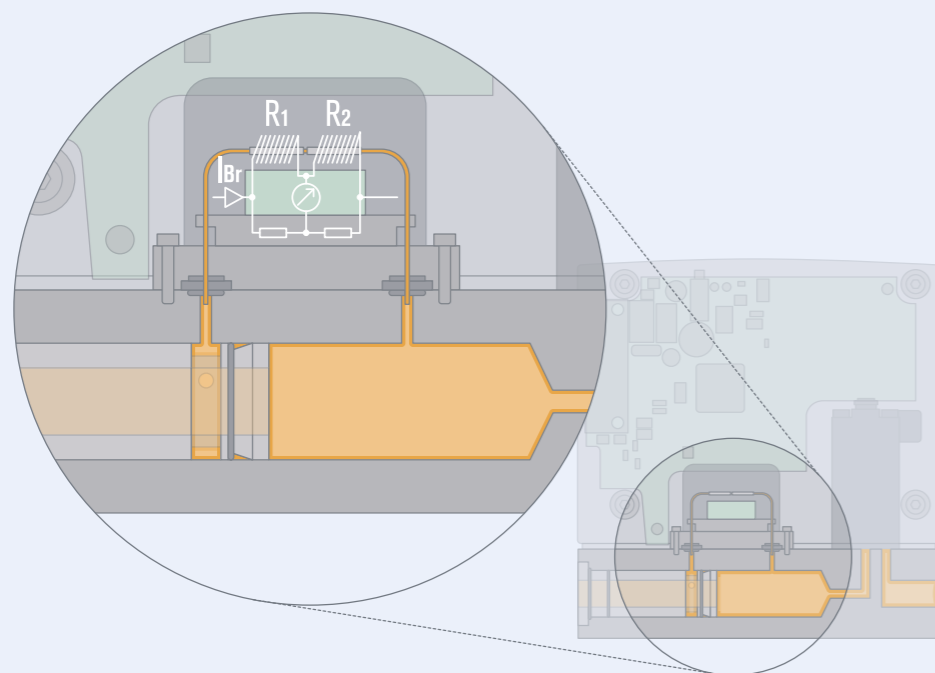

Fig. 4: Functional schematic of the bypass measuring principle

## Solenoid Control Valve

Solenoid control valves are electromagnetic control valves. They open to specific stroke positions – depending on the control signal. Two forces counter one another in the valve: one a spring, and the other generated by a magnetic field. In the power off state the pretensioned spring presses the plunger directly on to the valve seat, and the valve stays closed. If power is supplied to the coil a magnetic field is produced, which lifts the plunger against the spring force. The valve opens and the medium (gas) flows. The level of the coil current directly influences the magnetic force, the plunger stroke, the valve's opening degree, and therefore the amount of gas that flows through the valve. This simple, direct-acting construction keeps the control valves small, compact and cost-optimised. These are the properties that make solenoid control valves especially ideal for closed process control loops, where their precisely reproducible control positions and short response times make them particularly impressive.

The orifices of the valves are calculated from these parameters: required nominal flow rate ( $Q_{nom}$ ), the pressure conditions of the application, temperature and density of the operating gas (see: "Configuration" on page 18). MFCs with solenoid control valves in the orifice range of 0.05 mm to 12 mm have a wide full scale range.

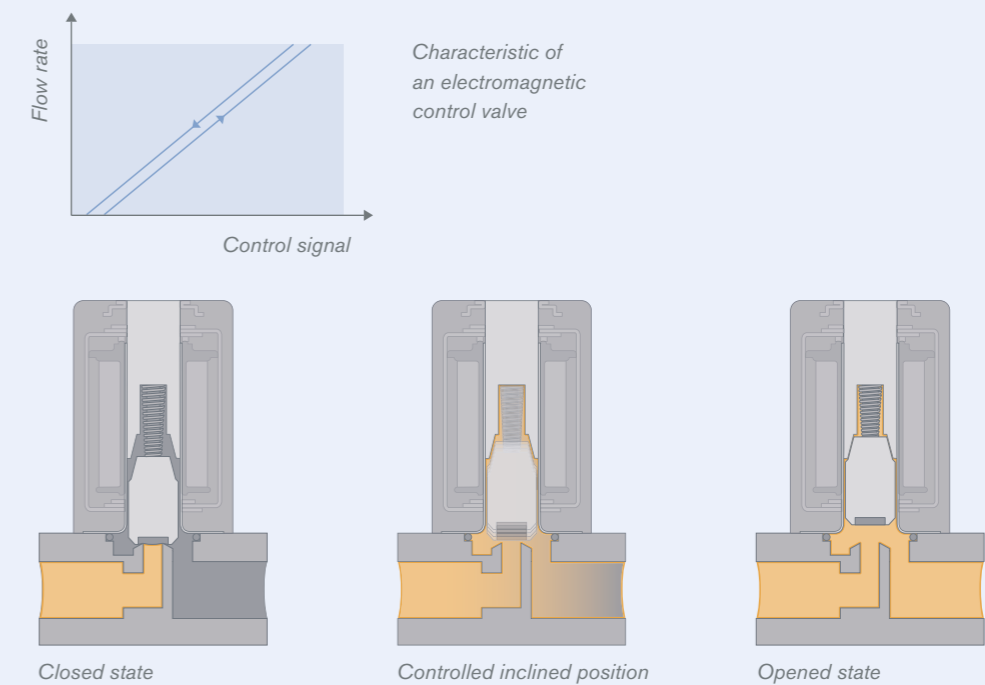

Fig. 5: Functional principle of direct-acting solenoid control valves

## Digital Control Electronics

The electronic microprocessor system processes the set point and actual flow rate values. In addition it also controls the actuator (solenoid control valve). The control electronics have the task of digitalising the analogue sensor signal. Using a calibration curve stored in the device, it converts the sensor signal into a value that corresponds to the actual flow rate value. The controller processes the control deviation  $x_d$  between set point value  $w$  and actual value  $x$  in accordance with a PI action, from which it calculates the correcting variable  $y$ , with which the actuator is controlled. The control parameters are set beforehand with the factory calibration. Because of the specific properties of each and every control process, the controller works with process-dependent amplification factors, which are automatically determined with an auto-optimisation routine (Autotune). Control dynamics, filter level and damping of the returned actual value signal – the MassFlowCommunicator communication software helps to adjust these settings later on. Depending on the device model, the set point value and actual value signals can be predefined and fed back either by analogue or digital technics: analogue via standard signal interface or digital via RS-232/RS-422 or fieldbus interface (Profibus, DeviceNet, CANopen and Modbus). The digital RS-232 or RS-422 interface is required for communication with the MassFlowCommunicator software (device-dependent). The microprocessor controlled electronics provide significant benefits: they reduce drift and offset occurrences of the components and enable software-based control of the most important processes (flash-programmed and update-enabled). The relevant data for this (calibration curves, correcting functions, control functions, etc.) can be stored in the memory.

**DeviceNet**  
CONFORMANCE TESTED

**CANopen**

**PROFIBUS**

**Modbus**





## Calibration

The sensor's measuring signal range is unambiguously assigned to the flow rate control or measuring range with the calibration. Extremely precise flow references are used to set the flow rate values and record the respective sensor signals. If the flow curve is registered, the electrical inputs and outputs can be calibrated, i. e. the flow range can be assigned to the signal range. Mass Flow Meters and Controllers are generally calibrated for a specific gas. Another gas can only be reliably controlled or measured when a second calibration curve has been stored. Exceptions to this are gases with similar properties, such as nitrogen and oxygen. A conversion factor across the entire flow range is sufficient. With devices with capillary sensors, access to conversion factors is sufficient with most gases because of the very low accuracy losses. Essentially every kind of gas mixture can be measured if its composition remains constant. MFMs/MFCs are often calibrated for the following gases: air, nitrogen, oxygen, argon, helium, hydrogen, methane, natural gas, propane, ammonia, carbon dioxide, carbon monoxide, sulphur dioxide or other various gas mixtures. If the highest precision is required, calibration with the operating gas (real gas calibration) is recommended in most cases. Aggressive gases cannot be real gas-calibrated. The flow references used in calibration test stands are based on DKD (Deutscher Kalibrierdienst/Deutschland – German Calibration Service, part of the PTB) and NIST (National Institute of Standards/USA). The PTB is a signatory of a global recognition agreement for calibration standards (MRA – Mutual Recognition Agreement).

burkert		Bürkert Fluid Control Systems Bürkert S.p.A.	
<b>Calibration Protocol</b> <b>Mass Flow Controller type 8626</b>			
Order No.:	07097517		
Device Ident No.:	00208496		Gas1
Nominal Flow Rate:	50.00 Nl/min		
Input Signal:	4...20 mA		
Output Signal:	4...20 mA		
Serial No.:	001000		
Software Revision:	A.90.04.00		
Calibration Reference:	Gauss, A. 1 0005.5, SN1530541, MD 4 m3/h		
Operating Gas:	Propane		
Calibration Gas:	Propane		
Inlet Pressure:	0.18 bar (g) referred to operating gas		
Leak-Tight Pressure:	bar (g) = 4.0		
Temperature:	27.1 °C		
Installation Position:	vertical, flow upwards		
Calibration Data:			
Flow Rate [%]	Reference [Nl/min]	Deviation [% P.S.]	Allowed Dev. [% P.S.]
0.00	0.000	0.00	0.30
25.00	24.411	0.14	0.68
50.00	24.928	0.14	1.05
75.00	27.626	-0.25	1.43
100.00	49.678	0.64	1.90
Calibration Date:	27/01/2009	Calibrator:	04000316
These data refer to the time and conditions of calibration.			

Fig. 6: A calibration certificate is created for each MFM/MFC after calibration. Two calibration certificates are provided for MFMs/MFCs supplied for the use of two gases or for devices with a wider measuring span.

## Additional functions

The MassFlowCommunicator communication software allows numerous additional functions to be programmed. To facilitate this the MFM/MFC is connected with a computer via an adapter. The following functions/options are available.

### Parametering

- Setting the control dynamics
- Selecting the standard signals for set point and actual value
- Setting a set point profile
- With multiple calibrations: Selection of an operating gas
- Assignment of functions to binary inputs:
  - Gas *changeover*
  - *Autotune*
  - *Resetting totalizers or limit value switches*
  - *Safety set point*
  - *Control operation (set point controls the valve directly)*
  - *Valve opening, e. g. for purging processes*
  - *And more*
- Assignment of functions to binary outputs:
  - *Error signalling*
  - *Control output, e. g. for shut-off valve*
  - *Limit value feedback (flow rate, totalizer)*
  - *And more*

### Diagnostics and service

- Control loop analysis
- Graphic illustration of the set point, the actual value and control value for the valve, over the respective period
- LED display for operating state
- Recalibration routine
- Firmware update
- Autotune function: automatic valve control range adjustment to the process conditions
- Standard signal calibration
- And more

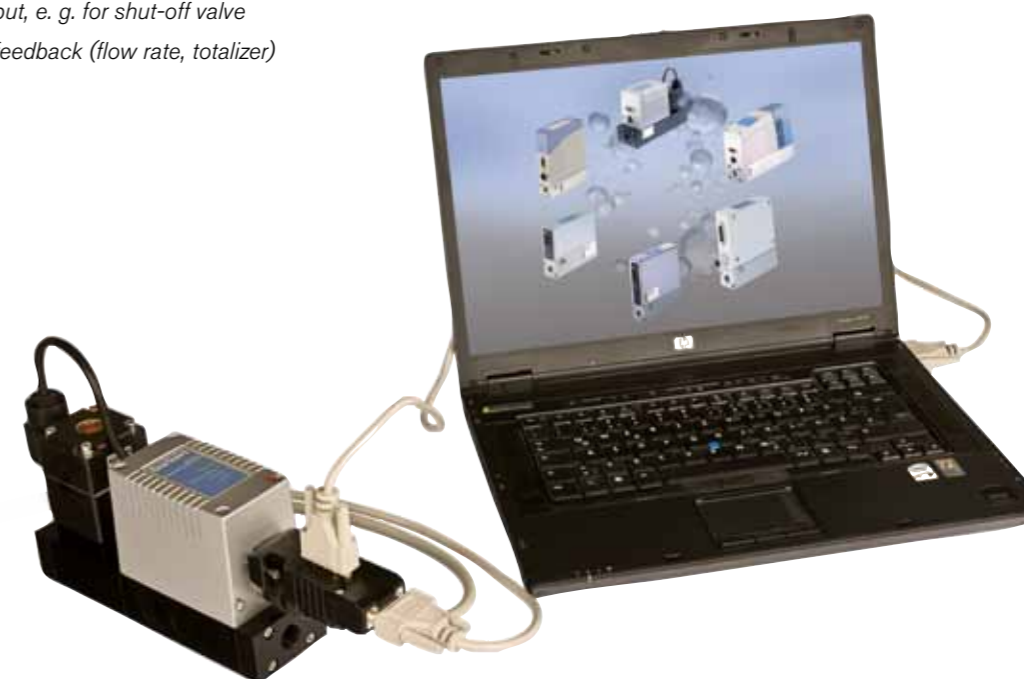

# Configuration

## Is the gas going to be controlled or just measured?

MFCs contain a solenoid control valve that sets the desired gas flow rate. MFMs however, only provide the current gas flow rate in the form of an actual value signal.

## What medium is to be controlled, dosed or measured?

MFMs/MFCs can be calibrated for a gas or gas mixture. If it is a gas mixture, an exact composition in percentages is important for configuring and calibrating the device. MFMs/MFCs with Inline or CMOS sensors need to be calibrated using the operating gas (real gas calibration) for both gases and gas mixtures. MFMs/MFCs with capillary sensors have a linear correlation between flow rate and measurement signal, allowing calibration with a neutral gas. The determined flow rate is corrected during operation using the conversion factor of the respective operating gas or gas mixture. The material compatibility of the MFMs/MFCs components must be ensured. The relative humidity can be almost 100%. A liquid state must, however, always be prevented. Particulate matter should be excluded with pre-filtering.

## What process data is available?

For an optimum MFM/MFC configuration some application data has to be available. Firstly the maximum flow rate ( $Q_{nom}$ ); according to the medium's normal density  $\rho_N$ . This can be determined with the known gas mixture composition. Next we require the medium temperature ( $T_1$ ) and the pressure values with the flow rate ( $Q_{nom}$ ) – measured immediately before and after the MFMs/MFCs ( $p_1, p_2$ ). The MFM/MFC  $k_v$  value is calculated with all this data (please see a data sheet of solenoid control valves). For the MFC's control properties it is important that the calculated MFM/MFC  $k_v$  value is greater than the  $k_v$  value of the overall system. With a too high  $k_v$  value, the resolution and therefore control qualities of the valve are impaired. If the setting is too low the MFC cannot achieve the required flow rate. The MFC authority (valve authority; please see appendix) should not be less than 0.3 ... 0.5. By dividing the maximum flow rate ( $Q_{nom}$ ) by the span, the minimum flow rate ( $Q_{min}$ ) can be calculated. For a guaranteed close tight function in all operating states, the maximum inlet pressure ( $p_{1max}$ ) is required.

## How do I communicate the set point and process value?

The control electronics are set up digitally. The interfaces can be configured as either analogue or digital. There is a choice of industry standard analogue signals, digital communication RS-232 or RS-422 or fieldbus (Profibus, DeviceNet, CANopen, Modbus).

8711 

**MFC/MFM applications - request for quotation**

▶ Please fill out and send to your nearest Bürkert sales centre\* together with your inquiry or order

Company	Contact person
Customer No.	Department
Address	Tel./Fax
Postcode/Town	E-mail

MFC-application   
  MFM-application   
  Quantity   
  Required delivery date

**Medium data**

Type of gas (or gas proportion in mixtures)

Density [kg/m<sup>3</sup>] <sup>1)</sup>

Medium temperature [°C or °F]  °C     °F

Moisture content [g/m<sup>3</sup>]

Abrasive components / solid particles   
 no   
 yes as follows

**Fluidic data**

Maximum flow  $Q_{max}$    
 l/min <sup>1)</sup>   
 cm<sup>3</sup>/min <sup>1)</sup>  
 m<sup>3</sup>/h <sup>1)</sup>   
 cm<sup>3</sup>/min (scm) <sup>2)</sup>  
 kg/h   
 l/min (slpm) <sup>2)</sup>

Minimum flow  $Q_{min}$    
 l/min <sup>1)</sup>   
 cm<sup>3</sup>/min <sup>1)</sup>  
 m<sup>3</sup>/h <sup>1)</sup>   
 cm<sup>3</sup>/min (scm) <sup>2)</sup>  
 kg/h   
 l/min (slpm) <sup>2)</sup>

Inlet pressure at  $Q_{nom}$      $p_1 =$   barg <sup>2)</sup>

Outlet pressure at  $Q_{nom}$      $p_2 =$   barg <sup>2)</sup>

Max. inlet pressure  $p_{1max}$      barg <sup>2)</sup>

Pipe run (external-Ø)   
 metric mm   
 imperial inch

MFC/MFM-port connection   
 without screw-in fitting  
 1/4" without screw-in fitting (DN ISO 228/1)  
 1/4" NPT-thread (ANSI B1.2)  
 with screw-in fitting  
 sub-base version

Installation   
 horizontal, valve upright (Standard)   
 horizontal, valve reclined  
 vertical, flow from above   
 vertical, flow from below

Ambient temperature     °C

**Material data**

Body material   
 Aluminum   
 Stainless steel  
 Seal material   
 FKM   
 EPDM   
 other:

**Electrical data**

Output/input signal	with standard signal		with fieldbus
	output	input	<input type="radio"/> PROFIBUS-DP
	<input type="radio"/> 0-5 V	<input type="radio"/> 0-5 V	<input type="radio"/> DeviceNet
	<input type="radio"/> 0-10 V	<input type="radio"/> 0-10 V	<input type="radio"/> CANopen
<input type="radio"/> 0-20 mA	<input type="radio"/> 0-20 mA		
<input type="radio"/> 4-20 mA	<input type="radio"/> 4-20 mA		

\* Please quote all pressure values as overpressures with respect to atmospheric pressure [barg]

1) at: 1.013 bar(a) and 0°C      2) at: 1.013 bar(a) and 20°C

To find your nearest Bürkert facility, click on the orange box → [www.burkert.com](http://www.burkert.com)

In case of special application conditions, please consult for advice.   
 Subject to alterations.   
 © Christian Bürkert GmbH & Co. KG   
 09053\_EU-en\_0091904

p. 6/6

# Typical Applications

The following illustrations demonstrate possible areas of application for MFMs/MFCs.

## Flame Control

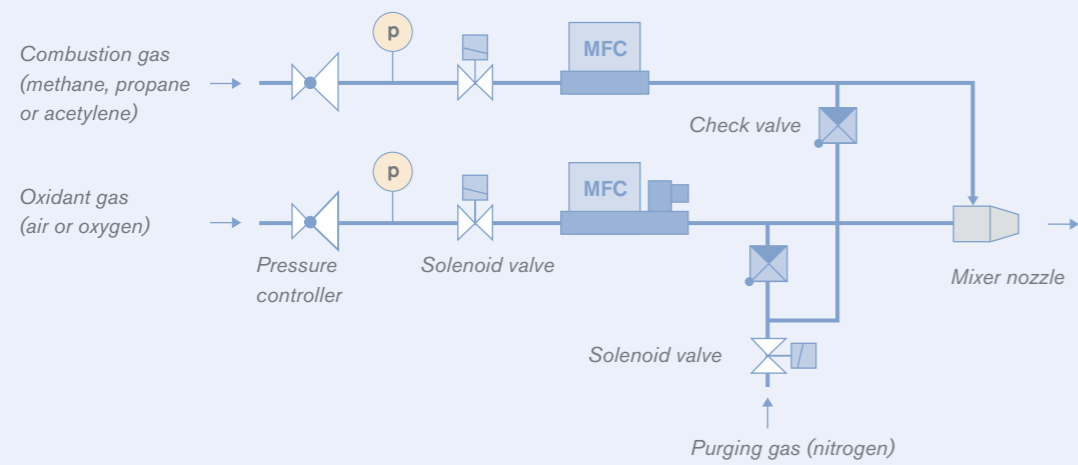

Fig. 7: MFCs and MFMs are used to provide combustion gas and oxygen in precise ratios.

## Plasma control

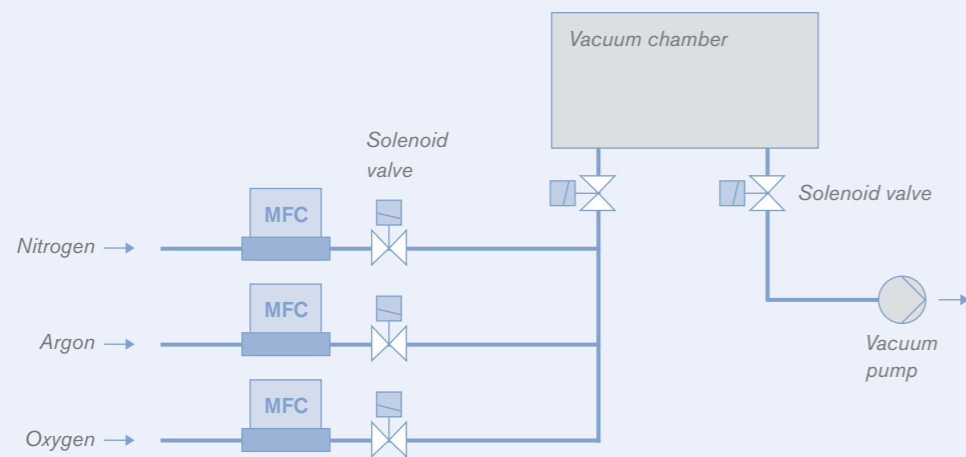

Fig. 8: MFCs precisely dose gas and gas mixtures into a vacuum chamber and therefore enable products to be processed in a plasma atmosphere.

## Atmosphere Control

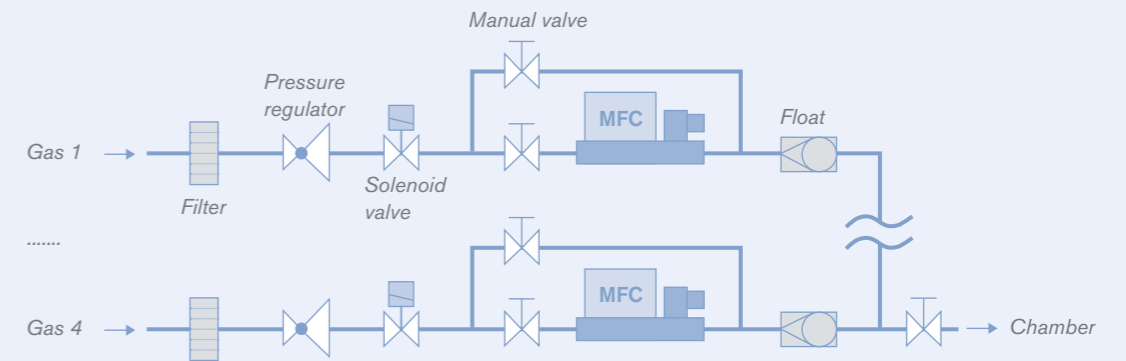

Fig. 9: The MFCs provide defined atmospheres to guarantee reproducible processes. The atmosphere volume can range from a specific point on a weld seam to the chamber volume of a hardening furnace.



## System Solutions

Gas handling applications vary, the technology is complex and the offering range is diverse. So obviously it is always easier if you have a partner at your side that has a long standing reputation that goes far beyond the development of high tech and innovative products. For more than 10 years, Bürkert has been established as a global leader in the provision of system solutions.

The advantages of Bürkert system engineering capabilities are convincing. With one single order number you can have a complete package to satisfy all your specific requirements. You are therefore free of procurement and installation work – and consequently the respective costs. For example Bürkert system solutions could consolidate a complicated series of valves, pipework and their respective connections, into a simplified and smart solution. The entire system is checked to ensure it is sealed tight and has fewer sealing points, which provides safety and security! In gas control applications numerous components interact with one another: These include solenoid valves, MFCs, sensors, switches, block-integrated check valves, integrated and replaceable filter elements and manual valves. These are all components that demand space. But a modular, compact installation is guaranteed if the entire system and technology come from one single source. With Bürkert's modular system engineering you have all the necessary, future proof options, because Bürkert's modular systems make later upgrades incredibly easy. Whether it is modifications to existing installations or for example, to provide additional valve positions today, which you may need some time in the future.

Bürkert provides system solutions to uncomplicate your world, through our experience, expertise and holistic competence.

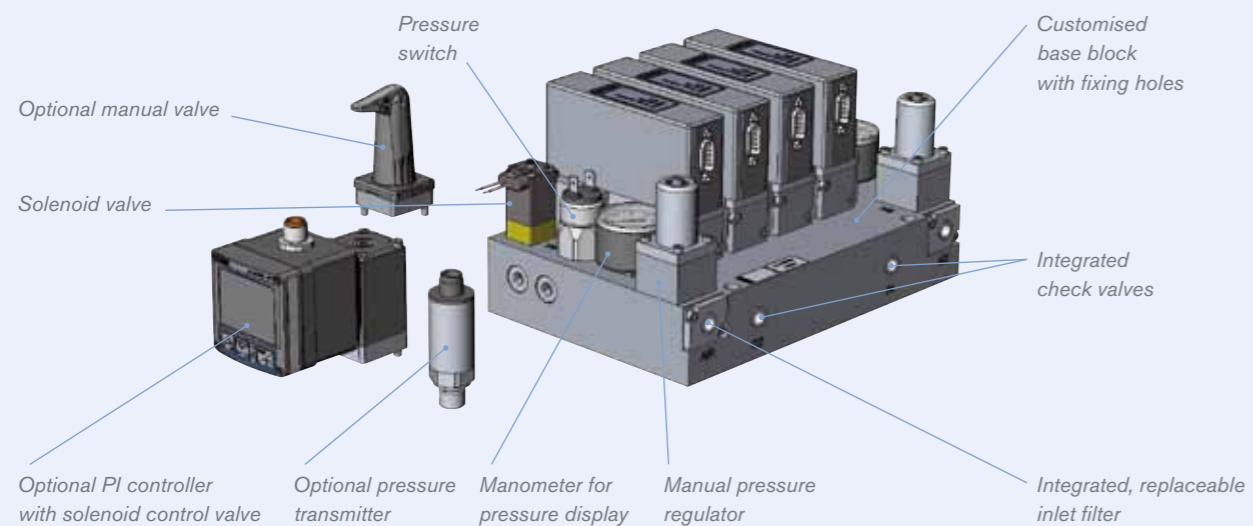

Fig. 10: System example



# Appendix

### Full scale range/Nominal flow $Q_{nom}$

The full scale range is the range of possible full scale values. The lowest value is the lowest possible full scale value/nominal flow rate; the highest value is the highest possible full scale value/nominal flow rate. The figures refer to defined reference conditions (e. g., standard litre per minute or standard cubic centimetre per minute).

### Operating medium/Calibration medium

The operating medium is generally used for calibration; in exceptional cases a reference gas (e. g., nitrogen) is used.

### Span

Given as a ratio, e. g. 1:50. Ratio of the smallest controllable flow rate value to the nominal flow rate.

### Settling time

Time that the MFC requires to achieve 95% of the difference between the old and the new flow rate value after a set point change; given in ms (milliseconds).

### Response time

Time the MFM needs to achieve 95% of the new value after a sudden flow rate change from  $Q_1$  to  $Q_2$ .

$$Q_{MFM}(t_{95}) = Q_1 + 0.95(Q_2 - Q_1)$$

### Accuracy

Given in  $\pm x\%$  of reading  $\pm y\%$  of full scale. The first value is a relative percentage; the second is a basic percentage.

### Repeatability

Given in  $\pm x\%$  of full scale. Repeatability is a mass for variation of actual values that result with repeated setting of a certain set point.

### $k_v$ factor (flow rate coefficient)

The  $k_v$  value is also called flow rate factor or flow rate coefficient. It is a unit for the achievable flow rate of a fluid or a gas through a valve and is used for selecting and dimensioning valves. The value is given in  $m^3/h$ . It corresponds with the water flow rate through a valve (in  $m^3/h$ ) at a pressure difference of 1 bar and a water temperature of 5 - 30°C.

### $c_v$ factor (flow rate coefficient)

Similar to the  $k_v$  factors, based, however, on the imperial measurement system. Given in US gallons per minute, at a pressure drop of 1 psi and 60°F temperature.

$$c_v = k_v * 1.17$$

### Normal conditions (DIN 1343)

Normal conditions are defined at

$$p_N = 1.013 \text{ bar absolute}$$

$$t_N = 0^\circ\text{C} (273 \text{ K})$$

### Standard conditions

Standard conditions are defined at

$$p_S = 1.013 \text{ bar absolute}$$

$$t_S = 20^\circ\text{C} (293 \text{ K})$$

### Density

Density ( $\rho$ ) provides the correlation between mass flow ( $\dot{m}$ ) and volume flow ( $\dot{V}$ ). The pressure and temperature conditions, the density is referred to, must be considered here (see above)

$$\rho = \dot{m}/\dot{V}$$

### Valve authority ( $\psi$ )

$$\psi = (\Delta p)_{v0} / (\Delta p)_0$$

$(\Delta p)_{v0}$  = MFC pressure loss at fully opened valve

$(\Delta p)_0$  = System pressure

Flow rate (volume)	$m^3/h$	$dm^3/h$	$dm^3/min$	$cm^3/h$	$cm^3/min$	cu ft/h	cu ft/min
1 $m^3/h$ =	1	$10^3$	16.67	$10^6$	$16.67 \cdot 10^3$	35.32	$58.87 \cdot 10^{-2}$
1 $dm^3/h$ (l/h) =	$10^{-3}$	1	$16.67 \cdot 10^{-3}$	$10^3$	16.67	$35.32 \cdot 10^{-3}$	$58.87 \cdot 10^{-5}$
1 $dm^3/min$ (l/min) =	0.06	60	1	$60 \cdot 10^3$	$10^3$	2.119	$35.32 \cdot 10^{-3}$
1 $cm^3/h$ (ml/h) =	$10^{-6}$	$10^{-3}$	$16.67 \cdot 10^{-6}$	1	$16.67 \cdot 10^{-3}$	$35.32 \cdot 10^{-6}$	$58.87 \cdot 10^{-8}$
1 $cm^3/min$ (ml/min) =	$60 \cdot 10^{-6}$	0.06	$10^{-3}$	60	1	$21.19 \cdot 10^{-4}$	$35.32 \cdot 10^{-6}$
1 cu ft/h (cfh) =	$28.32 \cdot 10^{-3}$	28.32	0.472	$28.32 \cdot 10^3$	472	1	$16.67 \cdot 10^{-3}$
1 cu ft/min (cfm) =	1.69	$1.69 \cdot 10^3$	28.32	$1.69 \cdot 10^6$	$28.32 \cdot 10^3$	60	1

Flow rate (mass)	kg/h	g/h	g/min
1 kg/h =	1	$10^3$	16.67
1 g/h =	$10^{-3}$	1	$16.67 \cdot 10^{-3}$
1 g/min =	0.06	60	1

Pressure	bar	mbar	Pa	Torr	psi
1 bar =	1	$10^3$	$10^5$	750.1	14.505
1 mbar =	$10^{-3}$	1	$10^2$	$750.1 \cdot 10^{-3}$	$14.50 \cdot 10^{-3}$
1 Pa = 1 N/m <sup>2</sup> =	$10^{-5}$	$10^{-2}$	1	$750.1 \cdot 10^{-5}$	$14.50 \cdot 10^{-5}$
1 Torr = 1 mmHg =	$1.33 \cdot 10^{-3}$	1.33	133	1	$19 \cdot 10^{-3}$
1 psi = 1 lb/in <sup>2</sup> =	$68.9 \cdot 10^{-3}$	68.95	$68.96 \cdot 10^2$	51.71	1

Temperature	°C	°F
	-10	14
	0	32
	10	50
	20	68
	30	86
	40	104
	50	122
	60	140
	70	158
	80	176
	90	194
	100	212

# Bürkert – Close to You

## Germany

### Sales Center

*Ingelfingen*  
Bürkert GmbH & Co. KG  
Christian-Bürkert-Straße 13-17  
DE-74653 Ingelfingen  
Tel: +49 (0)7940/10-91 111  
Fax: +49 (0)7940/10-91 448  
E-mail: info@buerkert.de

### Sales Offices

*Berlin*  
Bürkert GmbH & Co. KG  
Paradiesstraße 206 b  
DE-12526 Berlin  
Tel: +49 (0)30/679717-0  
Fax: +49 (0)30/679717-66

*Hannover*  
Bürkert GmbH & Co. KG  
Rendsburger Straße 18  
DE-30659 Hannover  
Tel: +49 (0)511/90276-0  
Fax: +49 (0)511/90276-66

*Dortmund*  
Bürkert GmbH & Co. KG  
Holzener Straße 70  
DE-58708 Menden  
Tel: +49 (0)2373/9681-0  
Fax: +49 (0)2373/9681-50

*Frankfurt*  
Bürkert GmbH & Co. KG  
Am Flugplatz 27  
DE-63329 Egelsbach  
Tel: +49 (0)6103/9414-0  
Fax: +49 (0)6103/9414-66

*Stuttgart*  
Bürkert GmbH & Co. KG  
Ulmer Straße 4  
DE-70771 Leinfelden-Echterdingen  
Tel: +49 (0)711/45110-0  
Fax: +49 (0)711/45110-66

*München*  
Bürkert GmbH & Co. KG  
Elsenheimerstraße 47  
DE-80687 München  
Tel: +49 (0)89/829228-0  
Fax: +49 (0)89/829228-50

## North- and South America

### Argentina

Bürkert-Contromatic Argentina S.A.  
Uruguay 2602, Centro Uruguay Norte,  
P.B. Oficina 1, (B1643EKP) Beccar,  
Pcia. de Buenos Aires, ARGENTINA  
Tel: +54 (0)11-5648-6350  
Fax: +54 (0)11-5648-6355  
E-mail: contacto.argentina@buerkert.com

### Brazil

Bürkert-Contromatic Brasil Ltda.  
Rua Américo Brasiliense, 2069  
Chacara Santo Antônio  
04715-005 São Paulo - SP BRAZIL  
Tel: +55 (0)11-2186 1155  
Fax: +55 (0)11-2186 1165  
E-mail: pedidos.brasil@buerkert.com

### Canada

Bürkert Contromatic Inc.  
5002 South Service Road  
Burlington, Ontario L7L 5Y7, CANADA  
Tel: +1 905-632 30 33  
Fax: +1 905-632 38 33  
E-mail: sales.ca@buerkert.com

### USA

BURKERT CONTROMATIC CORP.  
2915 Whitehall Park Drive, Suite 100  
Charlotte, NC 28273, USA  
Tel: +1 704-504 44 40  
Fax: +1 949-223 31 98  
E-mail: marketing-usa@buerkert.com

## Europe

### Austria

Bürkert-Contromatic G.m.b.H.  
Diefenbachgasse 1-3  
AT-1150 Wien  
Tel: +43 (0)1-894 13 33  
Fax: +43 (0)1-894 13 00  
E-mail: info@buerkert.at

### Belgium

Bürkert Contromatic BV  
Minervum 7220  
NL-4817 ZJ Breda  
Tel: +32 (0) 3 325 89 00  
Fax: +32 (0) 3 325 61 61  
E-mail: info@buerkert.nl

### Czech Rep.

Bürkert-Contromatic G.m.b.H. organizacni slozka  
Krenova 35  
CZ-602 00 Brno  
Tel: +420 543-25 25 05  
Fax: +420 543-25 25 06  
E-mail: obchod@buerkert.cz

### Denmark

Bürkert-Contromatic A/S  
Hørkær 24  
DK-2730 Herlev  
Tel: +45 44-50 75 00  
Fax: +45 44-50 75 75  
E-mail: info.dk@buerkert.com

### Finland

Bürkert Oy  
Atomitie 5  
FI-00370 Helsinki  
Tel: +358 (0)207 412 550  
Fax: +358 (0)207 412 555  
E-mail: sales.fi@buerkert.com

## Europe, continued

### France

BURKERT CONTROMATIC SAS  
Rue du Giessen  
FR-67220 Triembach au Val  
Tel: +33 (0)388-58 91 11  
Fax: +33 (0)388-57 20 08  
E-mail: burkert.france@buerkert.com

### Italy

Bürkert Contromatic Italiana S.p.A.  
Centro Direzionale „Colombiolo“  
Via Roma, 74  
IT-20060 Cassina De' Pecchi (MI)  
Tel: +39 02-959 07 1  
Fax: +39 02-959 07 251  
E-mail: info@buerkert.it

### Netherlands

Bürkert Contromatic BV  
Minervum 7220  
NL-4817 ZJ Breda  
Tel: +31 (0) 88 12 67 300  
Fax: +31 (0) 88 12 67 350  
E-mail: info@buerkert.nl

### Norway

Bürkert-Contromatic A/S  
Hvamstuppen 17  
NO-2013 Skjetten  
Tel: +47 63-84 44 10  
Fax: +47 63-84 44 55  
E-mail: info@buerkert.no

### Poland

Bürkert-Contromatic GmbH Oddzial w Polsce  
Bernardynska street 14 a  
PL-02-904 Warszawa  
Tel: +48 (0)22-840 60 10  
Fax: +48 (0)22-840 60 11  
E-mail: buerkert@buerkert.pl

### Portugal

Tel: +351 212 898 275  
Fax: +351 212 898 276  
E-mail: portugal@buerkert.com

### Spain

Bürkert Contromatic S.A.  
Avda. Barcelona, 40  
ES-08970 Sant Joan Despi, Barcelona  
Tel: +34 93-477 79 80  
Fax: +34 93-477 79 81  
E-mail: spain@buerkert.com

### Sweden

Bürkert-Contromatic AB  
Kattsundsgatan 27  
SE-211 26 Malmö  
Tel: +46 (0)40-664 51 00  
Fax: +46 (0)40-664 51 01  
E-mail: info.se@buerkert.com

### Switzerland

Bürkert-Contromatic AG Schweiz  
Bösch 71  
CH-6331 Hünenberg ZG  
Tel: +41 (0)41-785 66 66  
Fax: +41 (0)41-785 66 33  
E-mail: info.ch@buerkert.com

## Europe, continued

### Turkey

Burkert Contromatic Akiskan Kontrol  
Sistemleri Ticaret A.S.  
1203/8 Sok. No2-E  
TR-Yenisehir, Izmir  
Tel: +90 (0)232-459 53 95  
Fax: +90 (0)232-459 76 94  
E-mail: infoturkey@buerkert.com

### United Kingdom

Burkert Contromatic Limited  
Brimscombe Port Business Park  
Brimscombe, Stroud  
Glos, GL5 2QQ / UNITED KINGDOM  
Tel: +44 (0)1453-731 353  
Fax: +44 (0)1453-731 343  
E-mail: sales.uk@buerkert.com

## Africa

### South Africa

Bürkert Contromatic (Proprietary) Limited  
233 Albert Amon Road  
Millennium Business Park  
Meadowdale,  
Germiston  
(Postal: P.O. Box 26260, East Rand 1462)  
SOUTH AFRICA  
Tel: +27 (0)11-574 60 00  
Fax: +27 (0)11-454 14 77  
E-mail: sales.za@buerkert.com

## Asia & Pacific

### Australia

BURKERT CONTROMATIC AUSTRALIA PTY.  
LIMITED  
15 Columbia Way, Norwest Business Park  
Baulkham Hills, NSW 2153, AUSTRALIA  
Tel: +61 2 8853 6353  
Fax: +61 2 8853 6363  
E-mail: sales.au@buerkert.com

### Victoria

BURKERT CONTROMATIC AUSTRALIA  
PTY. LIMITED  
Unit 11/26-30 Howleys Road  
Notting Hill Victoria 3168  
Tel: 1300 888 868  
Fax: 1300 888 076

### Queensland

BURKERT CONTROMATIC AUSTRALIA  
PTY. LIMITED  
Unit 4/43 Sandgate Road  
Albion Queensland 4010  
Tel: 1300 888 868  
Fax: 1300 888 076

### Western Australia

BURKERT CONTROMATIC AUSTRALIA  
PTY. LIMITED  
Unit 8, 1st Floor, 85 Reid Promenade  
Joondalup WA 6027  
Tel: 1300 888 868  
Fax: 1300 888 076

### South Australia

BURKERT CONTROMATIC AUSTRALIA  
PTY. LIMITED  
Innovation House, First Avenue  
Mawson Lakes SA 5095  
Tel: 1300 888 868  
Fax: 1300 888 076

## Asia & Pacific, continued

### China

Burkert Contromatic (Suzhou), Co., Ltd.  
(System House) Unit A5, Suhong Square  
No. 81 Suhong West Road  
SIP Suzhou P.R. CHINA, 215021  
Tel: +86 512 6265 8498  
Fax: +86 512 6265 9773

Burkert Contromatic (Shanghai), Co., Ltd.  
(logistic and warehouse for BC China)  
Floor 2, block 6, 166 Mingdong Road  
Pudong New District  
Shanghai 201209, P.R. CHINA  
Tel: +86 21-5863 9990  
Fax: +86 21-5863 9968  
E-mail: info.chn@buerkert.com

### Beijing

Burkert Contromatic (Shanghai), Co., Ltd.  
Room A 1708, Luowa Building, No.203  
Er Qu Lizezhongyuan, Wangjing,  
Chaoyang District  
Beijing P.R. CHINA, 100102  
Tel: +86 10 6439 9783, 6439 9793  
Fax: +86 10 6439 9612

### Chengdu

Burkert Contromatic (Shanghai), Co., Ltd.  
B zone, 2nd floor,  
DongFangGuangYi office building  
33, Hua Tai Road  
LongTan city industrial zone, 2nd section,  
East 3rd ring Rd.  
Chengdu, CHINA 610051  
Tel: +86 28 8425 1434, 8425 1435  
Fax: +86 28 8425 1560

### Guangzhou

Burkert Contromatic (Shanghai), Co., Ltd.  
4F-1, Block B, No.1 Innovation Building  
No.63 Chuang Qi Road  
Shilou Town, Panyu District  
Guangzhou P.R. CHINA, 511447  
Tel: +86 20 3927 0268, 3927 0260  
Fax: +86 20 3927 0269

### Shanghai

Burkert Contromatic (Shanghai), Co., Ltd.  
Room 501/502 Xin Gai Nian Mansion  
No.39 Wu Zhong Road  
Shanghai P.R. CHINA, 200233  
Tel: +86 21 6486 5110  
Fax: +86 21 6487 4815

### Suzhou

Burkert Contromatic (Shanghai), Co., Ltd.  
Unit 11-12, 5th Floor, Block A  
No.5 Xinghan Street  
SIP Suzhou P.R. CHINA, 215021  
Tel: +86-512-6265 9881  
Fax: +86-512-6265 9882

### Hong Kong

Burkert Contromatic (China/HK) Limited  
Unit K, 9/Floor, Kwai Shun Industrial Centre  
No. 51-63 Container Port Road  
Kwai Chung, N.T., HONG KONG  
Tel: +852 2480 1202  
Fax: +852 2418 1945  
E-mail: info.hkg@buerkert.com

### India

Burkert Contromatic PVT Ltd  
Apex Towers, 1st Floor, No. 54 II Main Rd  
RA Puram  
Chennai 600 028, INDIA  
Tel: +91 (0)44-4230 3456  
Fax: +91 (0)44-4230 3232  
E-mail: sales.in@buerkert.com

### Japan

Burkert Ltd.  
1-12-15, Suidou, Bunkyo-ku  
Tokyo 112-0005, JAPAN  
Tel: +81 (0)3-5804-5020  
Fax: +81 (0)3-5804-5021  
E-mail: info.jp@buerkert.com

### Korea

Burkert Contromatic Korea Co., Ltd.  
C-401, Micro Office Bldg. 554-2  
Gasan-Dong, Keumcheon-Gu  
Seoul 153-803, KOREA  
Tel: +82 (0)2-3462 5592  
Fax: +82 (0)2-3462 5594  
E-mail: info.kor@buerkert.com

### Malaysia

BURKERT CONTROMATIC SINGAPORE PTE LTD  
2F-1, Tingkat Kenari 6  
Sungai Ara  
11960 Penang, MALAYSIA  
Tel: +60 (0)4-643 5008  
Fax: +60 (0)4-643 7010  
E-mail: info.sin@buerkert.com

### New Zealand

BURKERT CONTROMATIC NEW ZEALAND  
LIMITED  
44 Rennie Drive  
Airport Oaks, Auckland 2022  
NEW ZEALAND  
Tel: +64 (0)9-256 77 37  
Fax: +64 (0)9-256 77 47  
E-mail: sales.nz@buerkert.com

### Philippines

BURKERT CONTROMATIC PHILIPPINES, INC.  
8467 West Service Road, Km. 14, Sunvalley  
South Superhighway, Parañaque City, 1700  
Metro Manila, PHILIPPINES  
Tel: +63 (0)2-7766071 / 7764384  
Fax: +63 (0)2-7764382  
E-mail: info.rp@buerkert.com

### Singapore

BURKERT CONTROMATIC SINGAPORE PTE LTD  
51 Ubi Avenue 1, #03-14  
Paya Ubi Industrial Park  
Singapore 408933, SINGAPORE  
Tel: +65 6844 2233  
Fax: +65 6844 3532  
E-mail: info.sin@buerkert.com

### Taiwan

Burkert Contromatic Taiwan Ltd.  
9 F, No. 32, Chenggong Road, Sec. 1,  
Nangang District  
Taipei  
TAIWAN 115, R.O.C.  
Tel: +886 (0)2-2653 7868  
Fax: +886 (0)2-2653 7968  
E-mail: info.rc@buerkert.com