



# Product Overview Process and Control Valves

01 SOLENOID VALVES

02

03 PNEUMATICS

04 SENSORS

05 MICROFLUIDICS

06 MASS FLOW CONTROLLERS

07 SOLENOID CONTROL VALVES

## Content

4	Fascination Bürkert	34	Control and Communication
6	Make Your Perfect Valve	36	Pilot Valves
8	Valve Styles	38	Feedback Switches
12	Angle Seat Valves	40	Control Heads
14	Globe Valves	44	Positioners
16	Diaphragm Valves	48	Process Controllers PID
18	Materials and Connections	52	Intuitive Intelligence Inside
20	Configurations	54	Technology in the Field
22	Quarter Turn Valves	56	Market Oriented Solutions
24	Operators	58	Approvals Behind our Success
26	Manual	60	Added Value Systems
27	Electric	62	Contacts at Bürkert
28	Rotary		
29	Dual		
30	Classic		
32	ELEMENT		

## Modular Process Valve Market Leader

Across thousands of individual solutions and spanning dynamic conditions of global competition our mission is to work towards your success. We have decades of global experience and we have always been positioned at the forefront of process valve technology.

Our innovative approach to your success is to secure your process efficiency, lower your downtime, increase your safety and boost your competitive advantage. We intend to collaborate with you where we can share our process control and valve experience. All of our combined knowledge is available to you through consultation, engineering support, selection and commissioning.

We want to be your food cooking, water purifying, engine testing, textile dyeing, chemical synthesizing, automotive painting, aluminum extruding, vacuum holding, induction heating, pharmaceutical preparing, car washing, cosmetic making, beverage dispensing, power generating, aseptic filling, semiconductor slicing, fermentation controlling, peroxide batching, bread mixing, soup cooking, ozone sterilizing, die casting, chromatographic separating, air compressing, robot weld cooling, yogurt processing, winery networking, gold mining, thermoforming, foam expanding, analytics automating, laser cutting, gas mixing, ion exchanging, boiler monitoring partner.

Whether you need a single component or a complex system solution, we always focus on optimum process reliability, efficiency and economy and with our certified quality system in accordance with ISO 9000 – 9004 we do it right and on time.

Everyone in our organisation is interested in listening to you with the aim of presenting you with only the most appropriate solution fluently in your daily application language.

# Welcome to the Fascinating World of Fluid Control Systems

Measurement and control: When it comes to working with liquids and gases, we are at your side – as a manufacturer of sophisticated products, as a problem-solver with an eye for the big picture, and as a partner offering you reliable advice. Since we started in 1946, we have developed into one of the world's leading suppliers of Fluid Control Systems. At the same time we have kept our status as a family-owned business with a foundation of strong basic values to highlight the way we think and act.

## EXPERIENCE

There are things which are not inherently yours. You have to gather them bit by bit. You receive them from others. And you constantly have to acquire them anew. That is what makes them so valuable. Experience is one of those things. For instance, because of our many years of experience with process valves, we can provide our extensive services to you – from consulting, development, and 3D CAD simulating to testing and after-sales service. Whether individual product solutions or a pioneering new system for the entire control process: Benefit from our experience.

## COURAGE

Those who only work toward optimizing things that already exist will eventually reach the limits – technically, financially, or personally. In order to overcome these limits, courage is needed: the courage to be different and trust one's own ideas; the courage to venture into the unknown, searching for new ways to develop products that have never existed before. We have this courage. By pooling and utilizing our competencies across all sectors, you benefit from our cumulative knowledge of valves, actuators, pilots and controllers.

## CLOSENESS

There are things we simply take for granted. Only when they are gone, do we realize how important these things really were. This applies in particular to closeness. Without closeness, it is very difficult to build relationships and a good understanding of one another. As an established medium-sized company, we know that. And that is why we are always there for you. Working with you, we develop the best possible solutions for your projects in the area of process control. Our global presence in 35 locations enables us to press ahead with technical innovations for our customers around the world.

# Bürkert Product Program

We are one of the few suppliers on the market to cover the complete control loop. Our current product range extends from solenoid valves through process and analytical valves to pneumatic actuators and sensors.

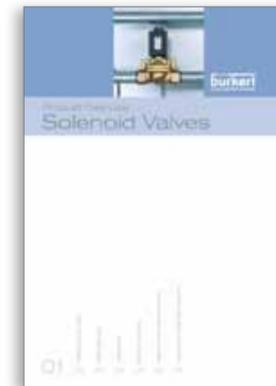

*Bürkert offers a remarkable range of servo assisted and direct acting solenoid valves. Read more about them in this brochure.*

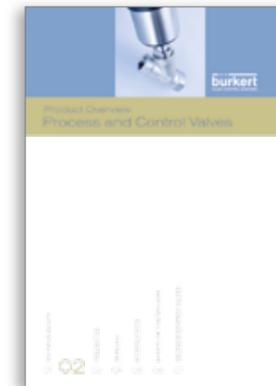

*Bürkert offers unlimited modularity for process control with angle-seat, globe and diaphragm valves in the widest range of configurations.*



*Here you can find our product range of pneumatic valves, valve units and automation systems as well as information on our control cabinet building.*



*Here you can find our sensors, transmitters and controllers for measuring and controlling flow, temperature, pressure, level, pH/ORP and conductivity.*



*The brochure contains an overview of Bürkert miniature valves and micro pumps, which allow for precise and safe handling of small volumes of liquids.*



*This brochure provides technical background information as well as a detailed product overview for the mass flow controller and meter product range.*



*This brochure presents our solenoid control valves including their respective features, functions and typical applications.*



# Make Your Perfect Valve

Making your life simpler, our groundbreaking innovation has created a remarkable range of attractive and hardworking valve elements which can be combined to give the user the best possible fit for purpose. With unlimited modularity, Bürkert saves you time by offering valves for media from slurries to steam and from de-ionized water to hydrochloric acid to offer peace of mind with the sure knowledge you have chosen experience and quality.



## Valve Style

We partner with you to choose the correct valve for your application. Starting with the body we can choose valves to control slurries, steam, aggressive liquids and materials which must remain pure. We offer four main methods for controlling fluids from our world renowned angle seat pattern to a range of quarter turn solutions. The choice is yours...

### Angle seat

- Robust
- Long life
- High flow



Page 12

### Globe

- Accurate
- Reliable
- Light



Page 14

### Diaphragm

- Media separated
- Hygienic
- Resistant



Page 16

### Quarter turn

- Full flow
- Moderate duty
- High pressure



Page 22

## Body Connections

We build a vast array of valves for a dispersed and diverse global process control market. Regional and industry based requirements are taken care of by our internal modular simplicity. No matter where you are in the world and which industry norm you are trying to meet, we have your connection.

Type	Norms available
Threads	ISO, NPT, RC
Solvent weld	ISO
Union	True union
Clamp	ISO, BS, DIN, ASME BPE
Welded	ASME BPE, BS OD, ISO, DIN
Flange	ANSI, DIN, JIS

## Body Materials

Our core competencies include modelling, machining and molding a vast array of engineering materials. We can supply materials compatibility advice and we know the material requirements inside many application environments. Our research and development laboratory is equipped to respond to our customers' demands for leading edge solutions and our efforts are focused towards your process success.

Metals used for bodies are	Engineered plastics used for bodies are
304	PVC
316L	PVDF
CF8M	PP
1.4571	
1.4435	
1.4435 BN2	
ASME BPE	
Hastelloy	
Titanium	
Tantalum	

## Body Finishes

All our valve bodies are machined and finished in house employing the latest computer controlled machines, the most dedicated people and the best measurement equipment.

Standard metallic body finishes in  $\mu\text{m}$  are listed below. Additionally electro-polishing is a common request from our clients which we have also made an internal competence.

Surface finish	6.3	3.2	2.7	1.6	0.89	0.75	0.625	0.51	0.375	0.28	0.25
Ra $\mu\text{m}$											
Ra $\mu\text{Inch}$	250	128	108	64	35	30	25	20	15	11	10
Grit					150		180	240	280	320	330

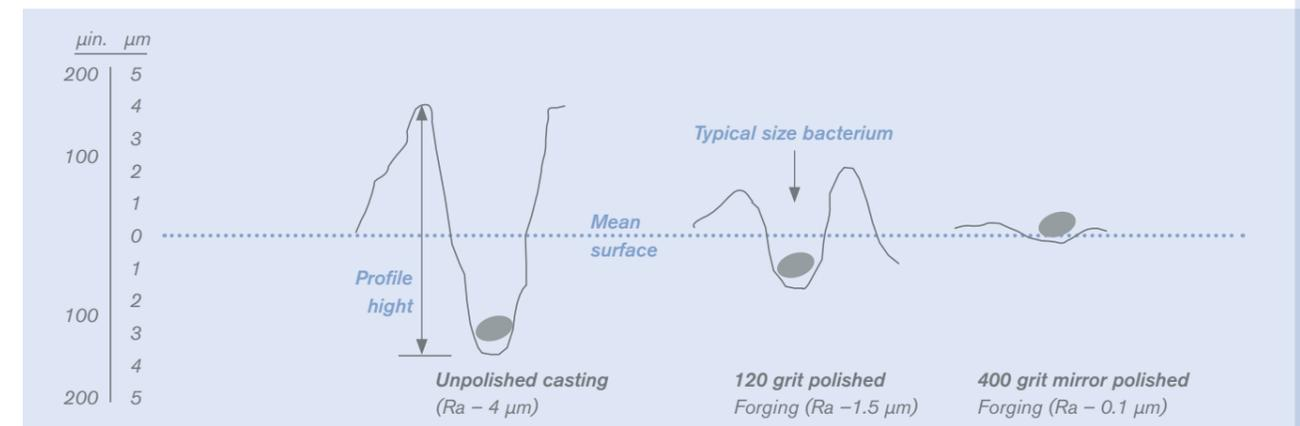

### Plastics

### Metals

Solvent



Union



Clamp



Thread

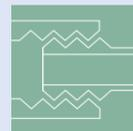

Clamp



Weld



Flange

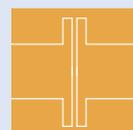

Additional valves also employ SteriCONNECT for ultrapure process systems using clamp, DIN union or flange connections. Details can be found in our Hygienic Processing Pharmaceutical brochure.

## Angle Seat On/Off Valves

The ideal alternative to complex actuated ball valves, the angle seat valve configuration is a real fit and forget solution. Bürkert's quality is evident. We are known as the market leader with this pattern and it is deployed successfully around the world in thousands of customer's machines and factories.

- Valve Body:** Gunmetal, Stainless steel 316L
- Seal:** PTFE as standard, others on request
- Port Types:** NPT, BSP Threaded, Weld End
- Function:** 2/2 Way
- Diameter Orifice:** 13 to 65 mm
- Flow:** 3.7 m<sup>3</sup>/h to 90 m<sup>3</sup>/h (approx)
- Nominal pressure:** PN 25
- Medium temperature:** -10 to 180° celcius

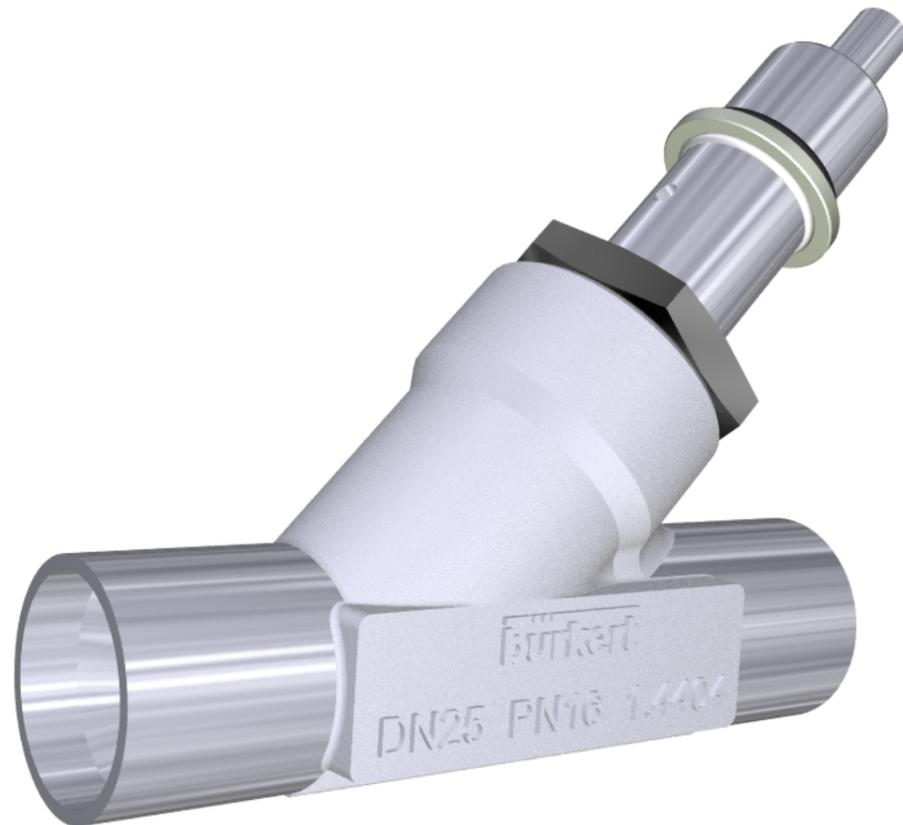

created by 3D sales technologies GmbH · info@3dst.de · www.3dst.de

## Angle Seat Control Valves

An uncomplicated control valve with large flows perfectly suited to steam, heat exchange and flow control applications. Our groundbreaking innovation provides you with superior features as standard. Bürkert has continuously improved its remarkable 2702 valve to meet our customers' demanding environments.

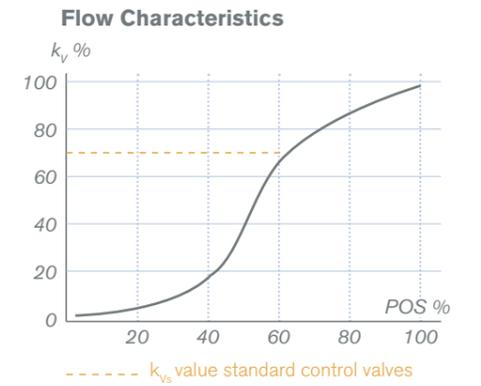

Uncomplicated and updated configuration and sizing tools are available online backed up with our local technical support.

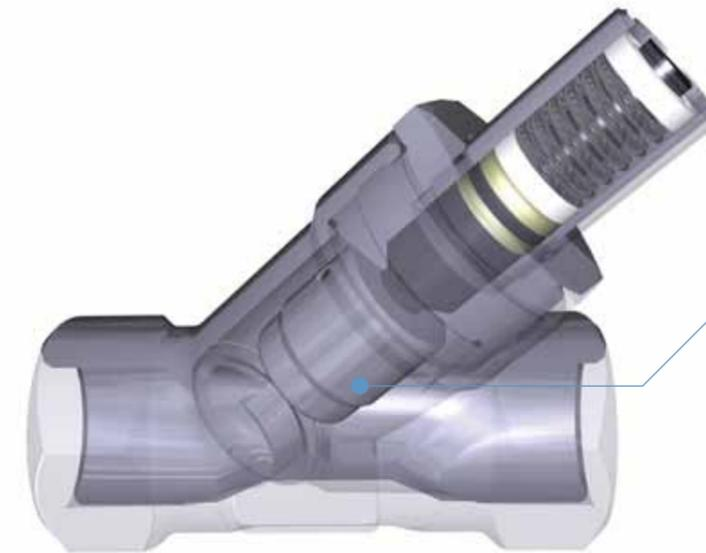

Control cone  
Metal / Metal Class IV  
Metal / PTFE Class VI

Classic type 2702  
ELEMENT type 2300



Valve	
Material	Stainless steel investment cast 316L
Port connection	Weld end in according to ISO 4200 DIN 11850, Series 2, BS4825, ASME BPE DN 10 – DN 50 (3/8 to 2 1/2")  Threaded port G, NPT and Rc DN 10 – DN 50 (3/8 to 2")
Nominal pressure	PN 25

Operating conditions	
Medium temperature	-10 to +180 °C
Ambient temperature	-10 to +60 °C High temperature version on request
Medium pressure	up to max. 16 bar
Options	Vacuum versions and valves which are cleaned for oxygen service are also available

## Globe On/Off Valves

A compact alternative to many pneumatically actuated valves, this globe pattern valve is especially convenient for smaller spaces or for connections requiring flanges. It is a fit and forget solution which carries Bürkert's angle valve quality.

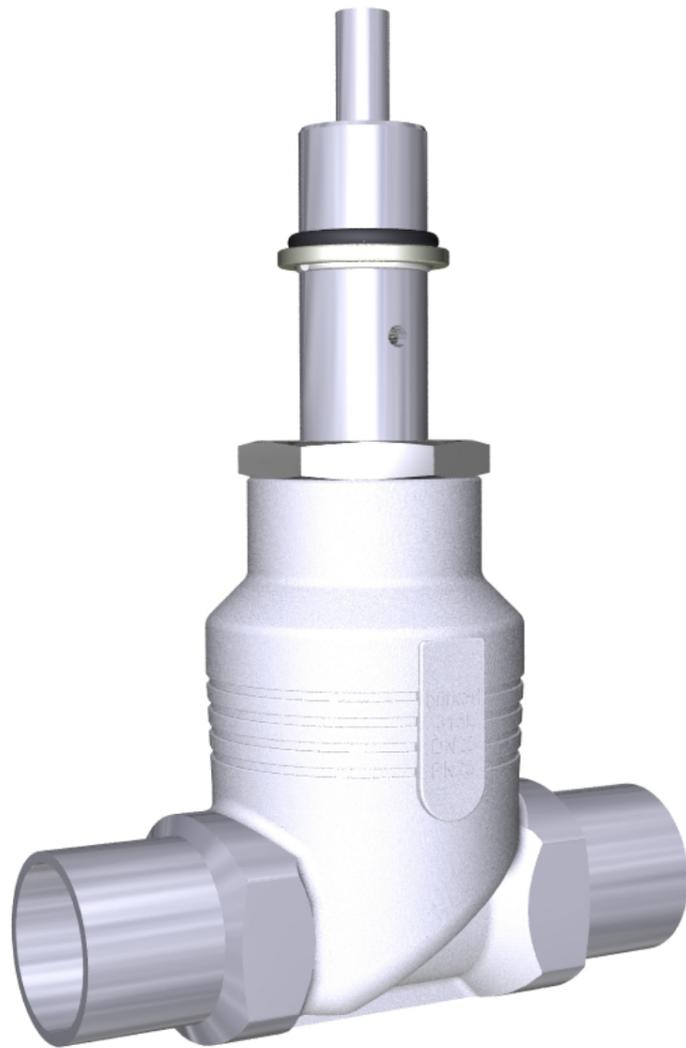

created by:JU-sales | technologies GmbH · info@jdstd.de · www.jdstd.de

## Globe Control Valves

A winning solution for many precise control applications, the globe control valve is the standard in many industries. Bürkert's idea is to take the standard to a new level in an ultra-compact, light weight envelope. These valves exhibit effective valve characteristics for continuous variation of the flow as a function of the parabolic plug position guided by a linear low friction stem.

Stainless steel or PTFE seals to give either Class IV or Class VI shutoff and each body size has a range of control plugs and corresponding replaceable seats for perfect sizing of any throttling application. Uncomplicated and updated sizing and configuration tools are available online backed up with our local unparalleled consulting and technical support.

### Flow Characteristics

3  $k_{vs}$  values per body size as standard feature

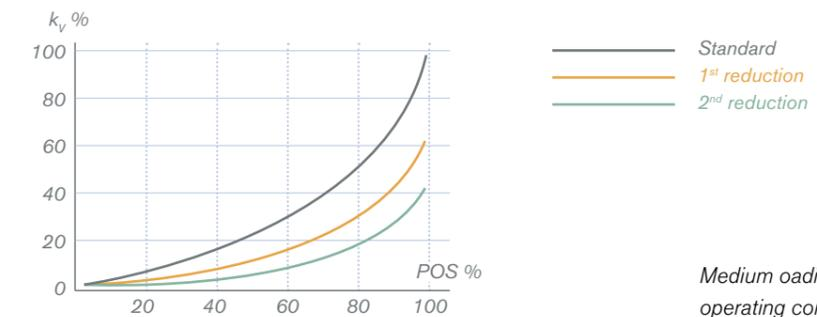

Medium oadin temperature and pressure and ambient operating conditions per Globe On/Off specifications

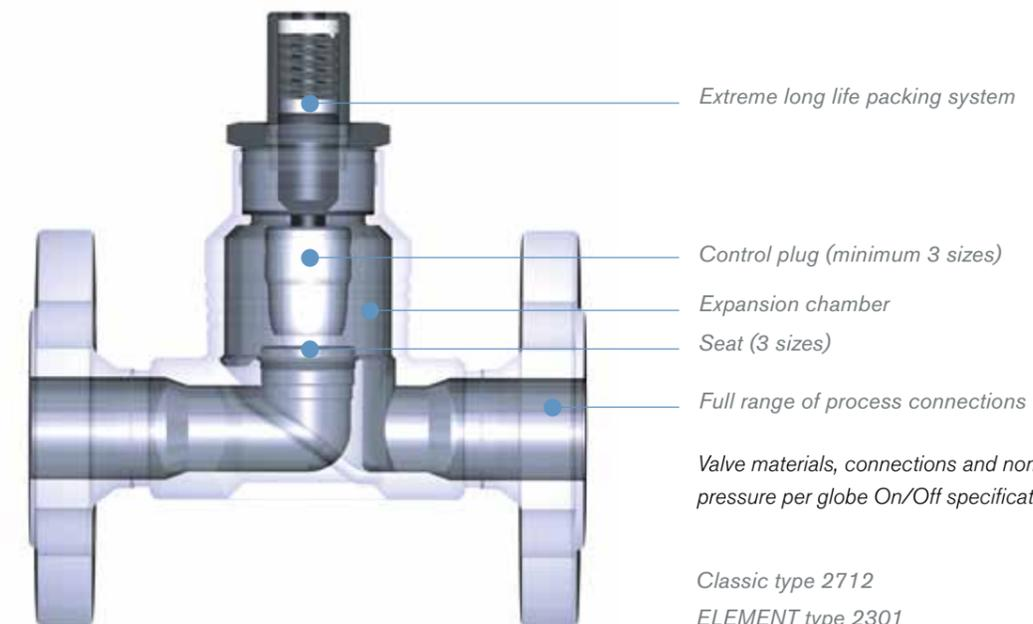

## Diaphragm On/Off Valves

Available in a wide range of plastic and metallic materials, this isolated and media resistant design has an excellent reputation for versatility and reliability in both aseptic and in industrial applications where corrosive, pure or abrasive media are controlled.

The diaphragm is the key performance component within a modular architecture and is relied on to provide leak-tight shutoff to the downstream side of the weir, to atmosphere and to the actuator mechanism.

Standard and customized diaphragm materials are offered for requirements of temperature, chemical resistance or specific USP certifications.

We continuously develop our understanding of all aspects of polymer and rubber technology, diaphragm design and lean production techniques.

The bodies can be provided to meet many surface finish requirements and usually are accompanied by a host of quality and industry specific certifications or approvals.

The weir pattern of the valve has a very favorable flow characteristic and is also drainable and abrasion resistant. We deliver cast and forged stainless steel, hydro-formed bodies and plastics with many different process connections to a wide variety of customers who expect their particular solution works every time.

Valve	
Material	Investment cast 316L – 1.4435 Forged 1.4435 BN2 – ASME BPE Hydroformed tube: 316L
Port connection	Flange according to DIN EN 1092-1 ANSI B1 6.5, JIS B2238 DN 10 – DN 100
	ISO 1127 - DIN 11850, BS4825 , ASME BPE, JIS DN 04 – DN 100
	Clamp: ISO, BS, DIN, ASME DN 04 – DN 100
	Threaded port G, NPT and Rc DN 10 – DN 65
Nominal pressure	PN 10



Classic types 2030, 2031, 3230  
Manual types 3232, 3233  
ELEMENT type 2103

## Diaphragm Control Valves

The weir pattern is quite unique in its ability to control very pure substances where a minimum of wetted materials and dead volumes are absolutely required although using a diaphragm valve without proper understanding of its inherent flow profile would present difficulties.

With the help of our range of very smart positioning software our diaphragm technology can be made to respond to the challenge of accurate and reliable flow and pressure control.

Our customers get all the resistance and drain-ability advantages of the weir pattern valve mixed with accurate control characteristics.

created by 3D Sales Technologies GmbH · info@3dst.de · www.3dst.de



## Materials, Sizes and Connections

Our diaphragm valves fulfill a large range of applications controlling pure, aggressive or contaminated fluids. We employ both engineered polymers and high quality metals according to your exact requirements of size, function, connection and wetted materials to provide higher process efficiency, process flexibility and optimum flow and cleanability.

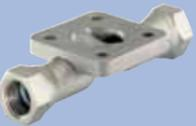
		Valve Bodies								
										
		PVC	PVDF	PP	Cold-formed pipe	Cast	Forged	PP	PVDF	Forged
Diameter orifice [mm]	8	■	■		■	■	■			■
	10	■	■		■	■	■			■
	15	■	■	■	■	■	■	■	■	■
	20	■	■	■	■	■	■	■	■	■
	25	■	■	■	■	■	■			■
	32	■	■	■	■	■	■			■
	40	■	■	■	■	■	■			■
	50	■	■	■	■	■	■			■
	65		■		■		■			
	80	■	■		■		■			
100	■	■		■		■				
Body connections	Union	■	■	■						
	Socket	■	■	■						
	Thread				■					
	Clamp					■	■	■	■	■
	Flange		■		■					
	Weld				■	■	■			■
Diaphragm material	PFR91							■	■	■
	PFA							■	■	■
	EPDM	■	■	■	■	■	■	■	■	■
	PTFE	■	■	■	■	■	■			

## Widest Range of Configurations

We truly have more to offer when it comes to diaphragm valves. Because we take the design back to first principles and build on our experience. The patented Robo pattern also adds endless possibilities which simply cannot be achieved with combinations of standard diaphragm valves. We do our best to help you visualize the benefits with online configurators and descriptive quotations and our people are trained to offer you only the best solution in your daily application language.



*In-line*

*Zero-static Tee*

*Tank bottom*

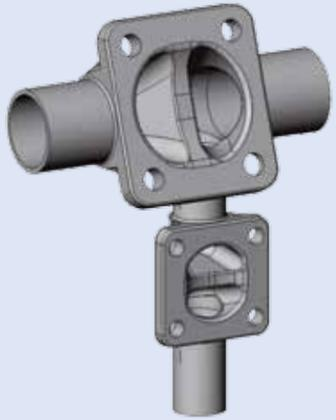
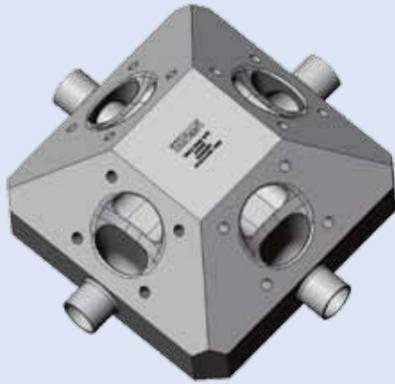
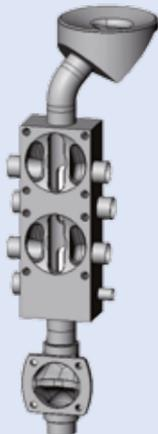
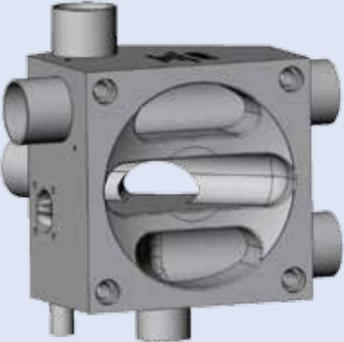
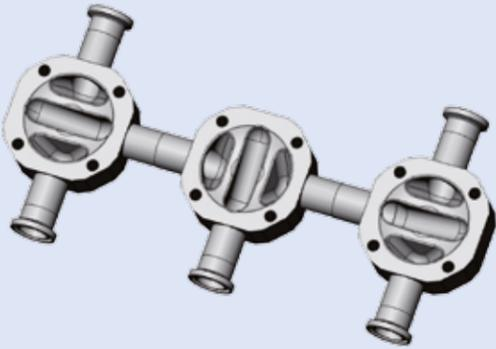
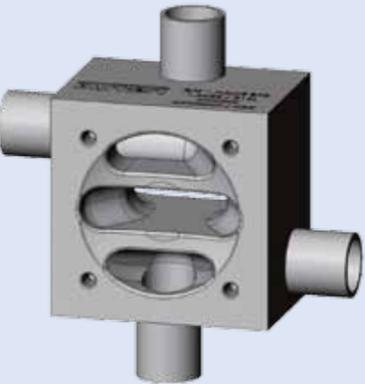
Weld	Block
	
	
	

## Quarter Turn – Ball Valves

All the quarter turn valves can be actuated manually, electrically or pneumatically and can also employ all of the possible feedback and control modules available from one source.



**Types 2657 | 2658 – True Union plastic ball valves**

True Union plastic ball valves, particularly suitable for industrial applications, where high performances and long time reliability are required. Longevity of the seals in situations where vibration or thermal expansion occurs.

**Type 8805 – Two piece ball valves**

Compact two piece full port ball valves. 316 stainless steel, a range of threaded ready to accept a locking device. Silicone free. Investment cast 316 stainless steel body with blow-out proof stem.



**Type 8805 – Three piece ball valves**

Compact three piece full port body in 316 stainless steel for a variety of applications with a range of end connection options.



**Type BBS-27 – BBS high purity – ball valve**

Pharmaceutical grade forged body ball valve for high pressure, high temperature, high purity liquids. It can be equipped with a manual handle or with pneumatic or electric actuators linking it to our full range of controllers and accessories like limit switches, pilot, positioners and manual override devices. Live-loaded pyramidal stem seal design.



## Quarter Turn – Butterfly Valves



**Type 2675 – Plastic butterfly valves**

Wafer style plastic butterfly valves are perfectly suited for a wide range of large line diameter and low pressure industrial applications. They can be manually, pneumatically or electrically actuated. Up to DN 200.

**Type 2672 – Metal butterfly valves**

2-way butterfly valve which can be manually, electrically or pneumatically operated. Body material is cast iron with a stainless disc. Available in size DN 50 to DN 100 these valves compliment our total process offering.



**Sanitary butterfly valves**

Sanitary butterfly body with optimised laser-cut operator connection to Bürkert's actuation systems. 3A certification for use in many hygienic processing applications. Optimized, lightweight and clean design makes this a perfect choice.



# Operators

Our wide range of valves require an equally flexible system of operators. At the center is our uncompromising modularity. Both manual and automated solutions are engineered with simplicity in mind.

Manual	Electric	Rotary	Dual	Classic	ELEMENT
<ul style="list-style-type: none"> <li>▪ Simple</li> <li>▪ Long life</li> <li>▪ Direct</li> </ul>  <p data-bbox="231 1906 379 1942">Page 26</p>	<ul style="list-style-type: none"> <li>▪ Strong</li> <li>▪ No air required</li> <li>▪ Slow &amp; precise</li> </ul>  <p data-bbox="706 1906 854 1942">Page 27</p>	<ul style="list-style-type: none"> <li>▪ Flexible</li> <li>▪ Interface ready</li> <li>▪ Light</li> </ul>  <p data-bbox="1181 1906 1329 1942">Page 28</p>	<ul style="list-style-type: none"> <li>▪ Unique</li> <li>▪ Feedback ready</li> <li>▪ Resistant</li> </ul>  <p data-bbox="1656 1906 1804 1942">Page 29</p>	<ul style="list-style-type: none"> <li>▪ Long life</li> <li>▪ Trusted</li> <li>▪ Interface ready</li> </ul>  <p data-bbox="2122 1906 2270 1942">Page 30</p>	<ul style="list-style-type: none"> <li>▪ Intelligence ready</li> <li>▪ Internal routed</li> <li>▪ Beautiful</li> </ul>  <p data-bbox="2597 1906 2745 1942">Page 32</p>

## Manual

The simplest and non-automated operation of valves plays an important role in all plants and machinery. Bürkert offers a wide range of manually operated valves and the operators are constructed to offer reliability and long life. Handwheels and levers must operate a wide variety of valves sizes from DN 8 to DN 150 and our program has evolved to be able to offer a wide range of materials and options. We concentrate on using materials which offer long term stability in demanding environments like PPS and stainless steel. Many of the manual solutions must offer the ability to be locked, stroke adjustment, digital or dial position indication and electrical feedback switches.



*Stainless handwheel and bonnet with visual indication and lockable option*



*Range of simple lever operators for ball and butterfly valves including lockable functions*



*Precision PPS bonnet and handwheel for small diaphragm valves*

Valve sizes	Materials	Features
DN 8 to DN 200	PPS x stainless, stainless x stainless	Locking, stroke adjustment, position indicator, feedback switches

## Electric

Bürkert's electrical actuators provide torques to suit many applications from 20 to 100 Nm. The actuators offer fast rotation times with all standard AC and DC voltages and using rugged electrical connections. Connection to many types of quarter turn valves is made through the ISO flange fixation from F03 to F07 with a female star drive adaptor. The actuators deliver both On/Off and analogue control through signal inputs and outputs of 0/4 - 20 mA and 0 - 10 VDC.



### Type 3003

Electric rotary actuator for quarter-turn valves with torques of 20, 35, 60 and 100 Nm. Manual override and visual position indicator.

### Type 3004

Explosion proof rotary actuator – On/Off and control. A compact, powerful actuator for use in hazardous areas. It provides a long service life and uses materials and components that have been chosen for maintenance-free operation. The modular design offers many options such as extra limit switches or potentiometers, to be added to the basic unit.



### Type 3005

Electric rotary actuator – for On/Off and control can be directly mounted on quarter-turn valves. Includes manual override and is corrosion resistant and protected to IP 67. Integral adjustable limit switches and multiple voltages are standard.

## Rotary

Bürkert offers a maintenance free actuator with a more compact and efficient design. Helical actuator principle turn linear air pressure force into torque to drive quarter turn valves. Smart, low friction, actuator design uses less air than other actuators and provides fast response times.

Materials such as PA or PPS are available combined with metal inserts for the pneumatic connection in brass or stainless steel, to provide increased chemical resistance and allow the use in high ambient temperatures.

Visual indication is a standard feature. The rotary actuator can interface with all pilot valves, feedback switches or positioners.



### Type 2050

Helical rotary actuator for quarter-turn applications is perfectly suited to accept all of the possible control and communications modules.

## Dual (Robolux)

Actuator specifically designed for our unique multiway multiport valves. Compact, smart and reliable they keep providing process efficiency and higher yields.

Inside are two individual pistons to drive compressors with no distance between them to create dead volume.

Outside powder coated aluminum, stainless steel or engineered polymer actuator housings are ready to accept standard inductive feedback switches.

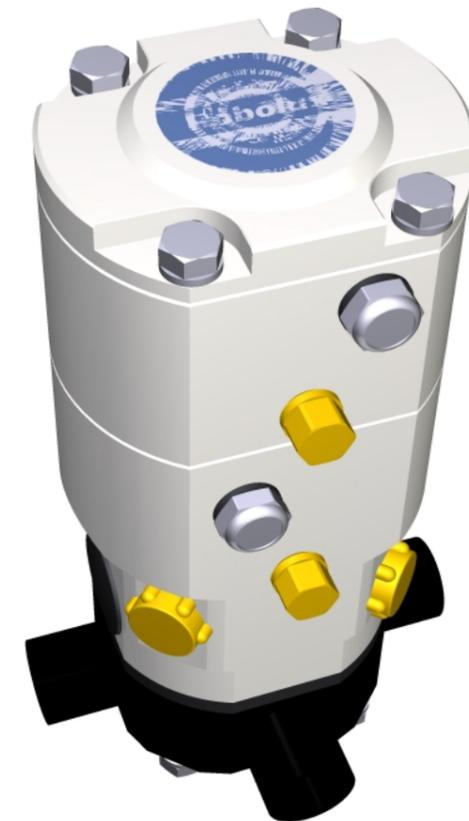

created by 3D Sales Technologies GmbH · info@3dst.de · www.3dst.de



## Classic

This actuator has been installed around the world in factories and in machines for an extremely wide variety of duties. It is known universally as the fit and forget actuator which just keeps going. The actuator is designed to use less energy through the use of clever volume fillers which do not impede the stroke and lasts longer because of the fact that each actuator part is molded in house according to our high quality standards and assembled almost completely within robot cells. The integrity of the inner surface of the cylinder and the flexible N-ring seal are the roots of the amazing lifespan.

A large range of diameters (40 mm, 50 mm, 63 mm, 80 mm, 100 mm, 125 mm, 175 mm, 225 mm) means that you only invest in what you need. The actuator employs polyamide (PA) for standard applications and polyphenylsulphone (PPS) for high ambient temperatures or superior chemical resistance. These normally open (NO), normally closed (NC), double acting heads are infinitely rotateable for pneumatic connection in your process.

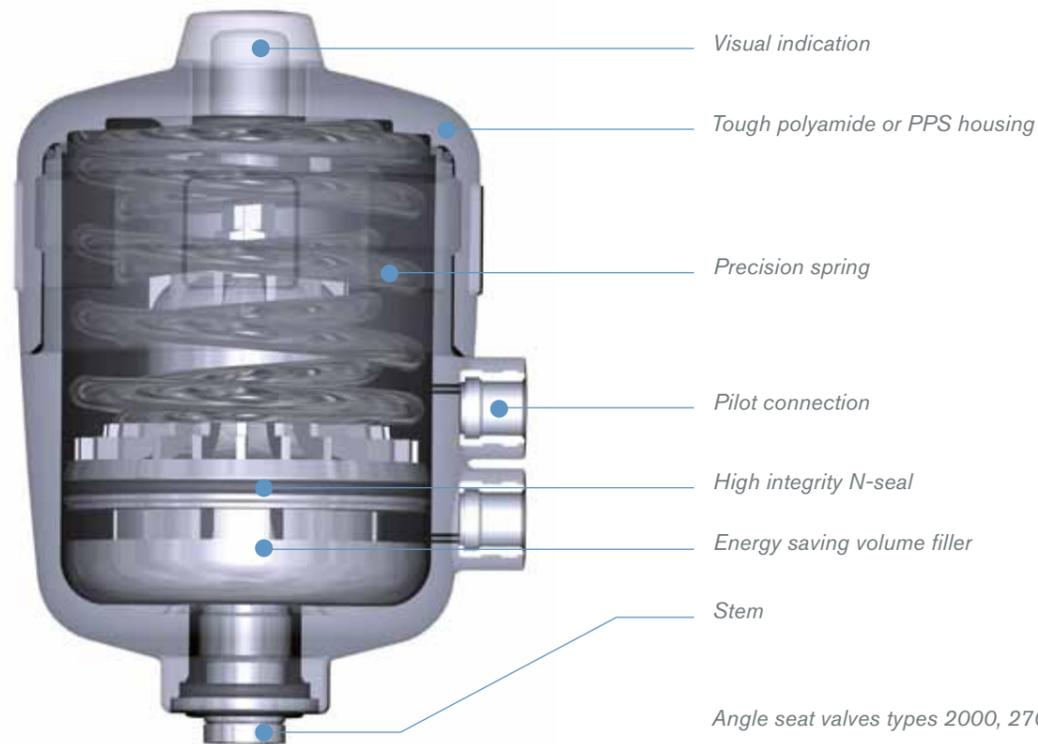

Angle seat valves types 2000, 2702.  
 Globe valves types 2012, 2712  
 Diaphragm valves types 2030, 2031, 3230,  
 2730, 2731.

created by 3D Sales Technologies GmbH · info@3dstd.de · www.3dstd.de

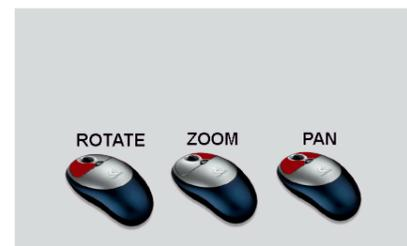

# ELEMENT

The ELEMENT actuators combine the engineering excellence of the classic actuators with a fresh new look. Chemical resistance and solid modular connections mix with the beautiful lines of a stainless steel valve with no external tubes or connections. The ELEMENT actuators are built to take advantage of the FreshAIR system so, unlike any other actuator system, each time the actuator strokes the spring chamber is replenished by clean instrument air. This means:

- no corrosion of the actuator springs
- no dirt inside the actuator
- no humidity transmitted into the control head through the spindle
- no biological contamination inside the actuator
- longer life

Highly cylindrical, precision molded parts reduce the chances of friction making these actuators perfect for both On/Off and control duties increasing the availability of fast, accurate control valve solutions wherever you are in the world.

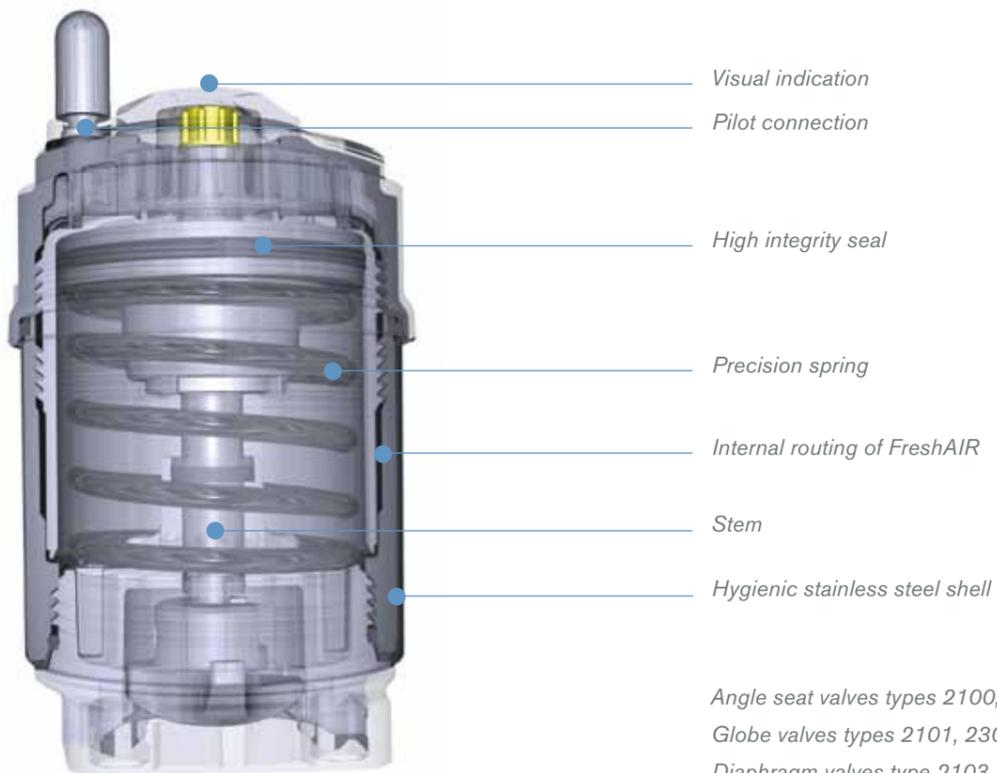

Angle seat valves types 2100, 2300.  
 Globe valves types 2101, 2301.  
 Diaphragm valves type 2103.

created by 3D Sales Technologies GmbH · info@3dstd.de · www.3dstd.de

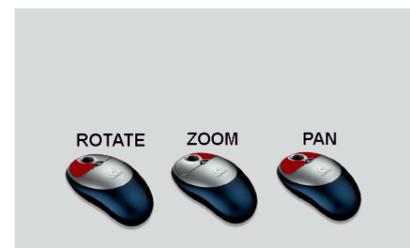

# Control and Communication

Bürkert offers the widest range of equipment to actuate, monitor, network, position and decentral-ize process control into the field. Each component is the product of cross functional mechanical and electrical engineering innovation and exacting laboratory testing. Each of the building blocks is ready to be included in your complete automation strategy.

	Pilot valves	Feedback switches	Control heads	Positioners	Process controllers
	<ul style="list-style-type: none"> <li>▪ Simple</li> <li>▪ Reliable</li> <li>▪ Manual override</li> </ul>	<ul style="list-style-type: none"> <li>▪ Secure</li> <li>▪ Flexible</li> <li>▪ Protected</li> </ul>	<ul style="list-style-type: none"> <li>▪ Modular</li> <li>▪ Networking</li> <li>▪ Teachable</li> </ul>	<ul style="list-style-type: none"> <li>▪ Display or blind</li> <li>▪ FreshAIR system</li> <li>▪ Accurate</li> </ul>	<ul style="list-style-type: none"> <li>▪ ProcessTUNE enabled</li> <li>▪ On-board PID</li> <li>▪ Graphic display</li> </ul>
	 <p>Page 36</p>	 <p>Page 38</p>	 <p>Page 40</p>	 <p>Page 44</p>	 <p>Page 48</p>
Actuate	▪		▪		
Monitor		▪	▪	▪	▪
Network			▪	▪	▪
Position				▪	▪
Control					▪

# Pilot Valves

It is your choice. From the simplest banjo valve to a fieldbus enabled off-road multichannel miracle. We fit within your flexible plant or latest blockbuster machine seamlessly.



**Types 6012P | 6014P – Banjo valves**

Multiple solutions based on our plunger style or pivoted armature valves. We offer a large range of voltages and process connections with all the right global certifications.



**Types 5470 | 6519 – Namur valves**

Simple and reliable set up is guaranteed by direct mount according to the namur standard interface. This solution is available in a large range of voltages and process connections.



**Manifold mount**

Valves arranged on metal or plastic manifolds where the environmental conditions demand the toughest solutions.

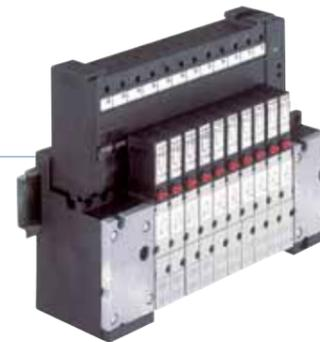

**Types 8640 | 8644 – Valve islands**

Valves arranged on plastic manifolds with common wiring or fieldbus options. Networking is achieved by the possibility to input feedback channels.



**Type 8645 – Valve islands (cabinet free)**

FreeLINE is designed to work outside the normal cabinet. It is a tough but modular solution which also has the possibility to accept feedback signals from the process valves it pilots.



## Feedback Switches

The security of knowing that a valve really switched is reassuring in many critical environments. We have packaged switches into a variety of housings to cover a wide range of application environments. From general purpose mechanical switches to solutions for hazardous locations we offer reliable peace-of-mind.

### Inductive switches

A simple system which accepts standard inductive threaded sensors.



### Type1060 – Simple open signal switch

This switch tells the operator that the valve has reached its fully open position. Reliable and inexpensive with SPDT 3A relays.



### Type 1062 – Mechanical or inductive switch

The switch that has been installed around the world as a standard for many years. The mechanical version conforms to the description of simple apparatus for hazardous locations. Pictured here in Ex version with tamper proof protection fitting.

### ELEMENT 8690 feedback package

Next generation feedback for both ELEMENT and Classic actuators. Contains mechanical or inductive feedback switches and can be easily connected to an AS-i network. A really rugged package that will survive the toughest wash down environments.



# Control Heads

A control head mixes the benefits of local pilot with feedback in one package. Bürkert has the advantage of being able to control the quality of the components inside as they are our own standard products. Add one, two or three pilot valves with mechanical, inductive or sensorpad feedback. Then plug and work.



					
Type	8690	8691	8695	8631	1066
Speciality	Simple strong connection to process valve	Compact integrated actuation without external air lines	Extremely compact integrated actuation without external air lines for 50 mm actuator	ATEX Zone 2 plant engineering EExi	Interface to hygienic and sterile valves IP 67
Pilot valves	1x 3/2- or 5/2-way with manual override	1x 3/2- or 5/2-way 2 with manual override	1x 3/2- or 5/2-way 2 with manual override	1x 3/2- or 5/2-way with manual override	Up to 3x 3/2-way with manual override
Feedback	2	2 switch points on an analog contactless, wear-free displacement transmitter	2 switch points on an analog contactless, wear-free displacement transmitter	2 inductive	3 inductive or 2 micro switches
Communications		AS-Interface DeviceNet	AS-Interface	AS-Interface DeviceNet	AS-Interface DeviceNet
Set-Up	Manual	Simple, one button, reliable drive adaption by TEACH calibration	Simple, one button, reliable drive adaption by TEACH calibration	Manual	Manual
Features	<ul style="list-style-type: none"> <li>▪ FreshAIR</li> <li>▪ Flush function</li> </ul>	<ul style="list-style-type: none"> <li>▪ On board air filter</li> <li>▪ ATEX Zone 2/22</li> <li>▪ SuperBRIGHT visual feedback</li> </ul>	<ul style="list-style-type: none"> <li>▪ On board filter</li> <li>▪ ATEX Zone 2/22</li> <li>▪ SuperBRIGHT visual feedback</li> </ul>	<ul style="list-style-type: none"> <li>▪ Resistance to cleaning agents</li> <li>▪ Manual override</li> <li>▪ FM IS / I, II, III / ABCDEFG approved</li> <li>▪ PTB EEx ia IIC T6 approved</li> <li>▪ According to ATEX</li> </ul>	<ul style="list-style-type: none"> <li>▪ Integrated relief valve</li> <li>▪ Multiple adaptors to various hygienic valves</li> </ul>

## Positioners Functional Advantages

A positioner is made from three distinct parts; a displacement transducer for detecting the position of the valve in its stroke, some control electronics, and finally, a set of valves to supply or release the pneumatic power.

The pneumatic valves allow air in or out of the actuator according to the desired position. The displacement measures how far away from the desired position the valve is and the control electronics determine the amount of air which should be exhausted or added.

For basic operation the positioner only needs a command signal, air and power but these positioners are packed with lots of time and money saving extras, offer flexible opportunities for optimizing the function for the application.

Positioner specific valve software functions like close tight cut-off, inversion, free customized characteristic, start position, and split range provide the perfect collection of advantages.

These functions are selected as needed offering a complete automation concept for integration into the most up-to-date control systems. All Bürkert positioners are based on the same operating structure, which unites the features of simple and clear operation.

Designed for tough and agile process environments the positioner's design optimizes size, shape and cleanability, footprint and access code security.

created by 3D Sales Technologies GmbH · info@3dstd.de · www.3dstd.de



# Positioners

A range of solutions to fit your requirements from simple cabinet mounted, DIP switch programmable blind positioner to a sleek, bus compatible with backlit display and intuitive programming.



							
Type	8692	8694 BASIC	8696 BASIC	8630	8792	8791 BASIC	8635
Speciality	Large backlit display Great look and feel	Inexpensive solution for perfect positioning with TEACH function	Inexpensive solution for perfect positioning with ELEMENT function	Interface to Classic actuators	Yoke mountable Rotary input Remote mount	Cabinet based	Rugged, HART compatible, 2-wire device ATEX Zone 1 engineering
Input	4 - 20 mA, 0 - 20 mA, 0 - 5 VDC, 0 - 10 VDC Binary input	4 - 20 mA Binary input	4 - 20 mA Binary input	4 - 20 mA, 0 - 10 VDC Binary input	4 - 20 mA, 0 - 20mA, 0 - 5 VDC, 0 - 10 VDC Binary input	4 - 20 mA Binary input	4 - 20 mA, 0 - 10 VDC Binary input
Measurement	Contactless inductive sensor	Contactless inductive sensor	Contactless inductive sensor	Linear potentiometer	Potentiometer	Remote	Remote
Communications	Profibus DPV1 DeviceNet	4 - 20 mA AS-Interface	4 - 20 mA	Profibus DPV1 DeviceNet	Profibus DPV1	None	Profibus
Output	Binary (2) 4 - 20 mA	Binary (2) 4 - 20 mA (position)	Binary (2) 4 - 20 mA (position)	4 - 20 mA (position)	Binary (2) 4 - 20 mA	4 - 20 mA	Binary (2) 4 - 20 mA
Features	<ul style="list-style-type: none"> <li>▪ Air filter</li> <li>▪ FreshAIR</li> <li>▪ Chemical resistance</li> </ul>	<ul style="list-style-type: none"> <li>▪ Air filter</li> <li>▪ FreshAIR</li> <li>▪ Chemical resistance</li> </ul>	<ul style="list-style-type: none"> <li>▪ FreshAIR</li> <li>▪ Chemical resistance</li> </ul>	<ul style="list-style-type: none"> <li>▪ Single line display</li> </ul>	<ul style="list-style-type: none"> <li>▪ On board filter</li> <li>▪ ATEX Zone 2/22</li> <li>▪ Single and double acting actuators</li> </ul>	<ul style="list-style-type: none"> <li>▪ IP 20</li> <li>▪ Dip switch setup</li> <li>▪ Single and double acting actuators</li> </ul>	<ul style="list-style-type: none"> <li>▪ Display inside case</li> <li>▪ Chemical resistance</li> <li>▪ Aluminum case</li> </ul>

## Positioners Functional Advantages

A positioner is made from three distinct parts; a displacement transducer for detecting the position of the valve in its stroke, some control electronics, and finally, a set of valves to supply or release the pneumatic power.

The pneumatic valves allow air in or out of the actuator according to the desired position. The displacement measures how far away from the desired position the valve is and the control electronics determine the amount of air which should be exhausted or added.

For basic operation the positioner only needs a command signal, air and power but these positioners are packed with lots of time and money saving extras, offer flexible opportunities for optimizing the function for the application.

Positioner specific valve software functions like close tight cut-off, inversion, free customized characteristic, start position, and split range provide the perfect collection of advantages.

These functions are selected as needed offering a complete automation concept for integration into the most up-to-date control systems. All Bürkert positioners are based on the same operating structure, which unites the features of simple and clear operation.

Designed for tough and agile process environments the positioner's design optimizes size, shape and cleanability, footprint and access code security.

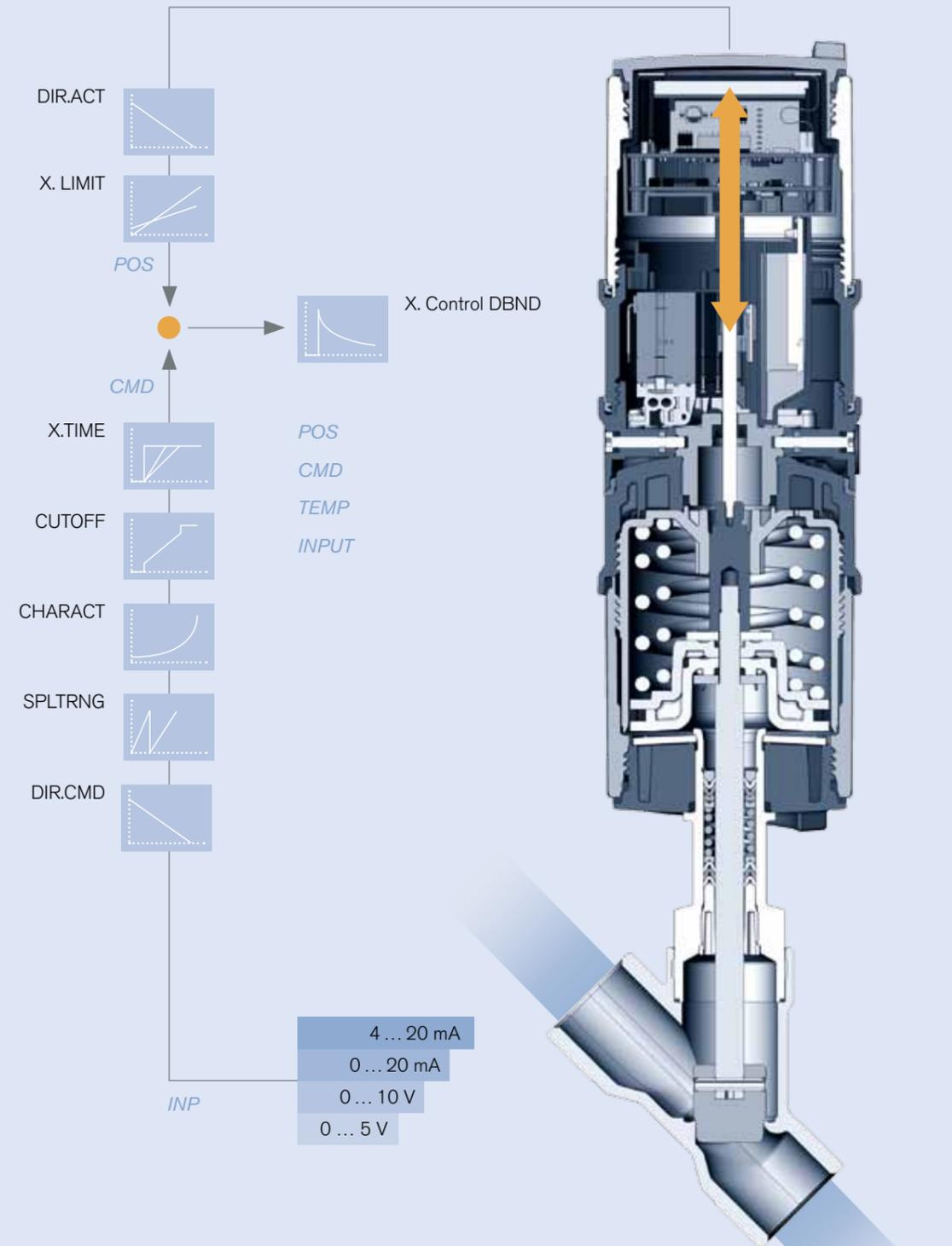

# Process Controllers with PID On Board

Bürkert was the pioneer of real on-valve process intelligence. Cross competence innovation in the interface between control electronics and mechanical precision resulted in a range of perfect decentralized control solutions to make your world simpler. Each one capable of replacing multiple components from traditional control loops, they are simple to install and configure.

With our ProcessTUNE we really have made PID as simple as your car's cruise control. Take a test, drive as soon as you can.



Type	8693	8630	8793	8635
Speciality	ProcessTUNE enabled package for ELEMENT and Classic actuators	Large, single line display	Yoke mounted or rotary input controller with ProcessTUNE	2-wire ATEX Zone 1
Input	RTD (Pt100), Pulse, 4 - 20 mA	RTD (Pt100), Pulse, 4 - 20 mA	RTD (Pt100), Pulse, 4 - 20 mA	RTD (Pt100), Pulse, 4 - 20 mA
Measurement	Contactless inductive sensor	Linear potentiometer	Remote sensor, yoke sensor or rotary sensor	Remote sensor
Communications	DeviceNet, Profibus DPV1	DeviceNet, Profibus DPV1	DeviceNet, Profibus DPV1	Profibus PA
Output	4 - 20 mA, 2 binary	4 - 20 mA, 2 binary	4 - 20 mA, 2 binary	4 - 20 mA, 2 binary
Features	<ul style="list-style-type: none"> <li>▪ Security measures</li> <li>▪ Large intuitive graphic display</li> <li>▪ Advanced Process TUNE</li> <li>▪ ATEX Zone 2/22</li> </ul>	<ul style="list-style-type: none"> <li>▪ Single line display</li> <li>▪ Integrates to Classic actuator</li> </ul>	<ul style="list-style-type: none"> <li>▪ Simple, one button, reliable drive adaption by TEACH calibration</li> <li>▪ ATEX Zone 2/22</li> <li>▪ Large intuitive graphic display</li> </ul>	<ul style="list-style-type: none"> <li>▪ Rugged aluminum case</li> <li>▪ Interfaces with 2-wire 4 - 20 mA loop II (1) 2 G EEx ia IIC T6</li> </ul>

## Process Controller Functional Advantages

Process variables such as temperature, pressure, flow rate or level are crucial to process engineering sequences.

The actual process value is detected by means of a suitable sensor in the pipe and compared to the process set-point.

Depending on the magnitude and operational sign of control deviation, the process controller computes the position set-point for the position control loop. The process variable is then changed by opening or closing the valve. Continuous measurement of the actual process value and comparing it with the process set-point minimizes the control difference between the two values.

### Operating structure of the positioners

Inside this small package is an intuitive, fast reliable controller with advanced ProcessTUNE. Add to this specific valve software functions like close tight cut off, inversion, free customized characteristic, start position, and split range and you have the perfect collection of advantages.

Distributed intelligence with a clear connection through standard bus protocols, to the coordination and supervisory level is an important part of the design.

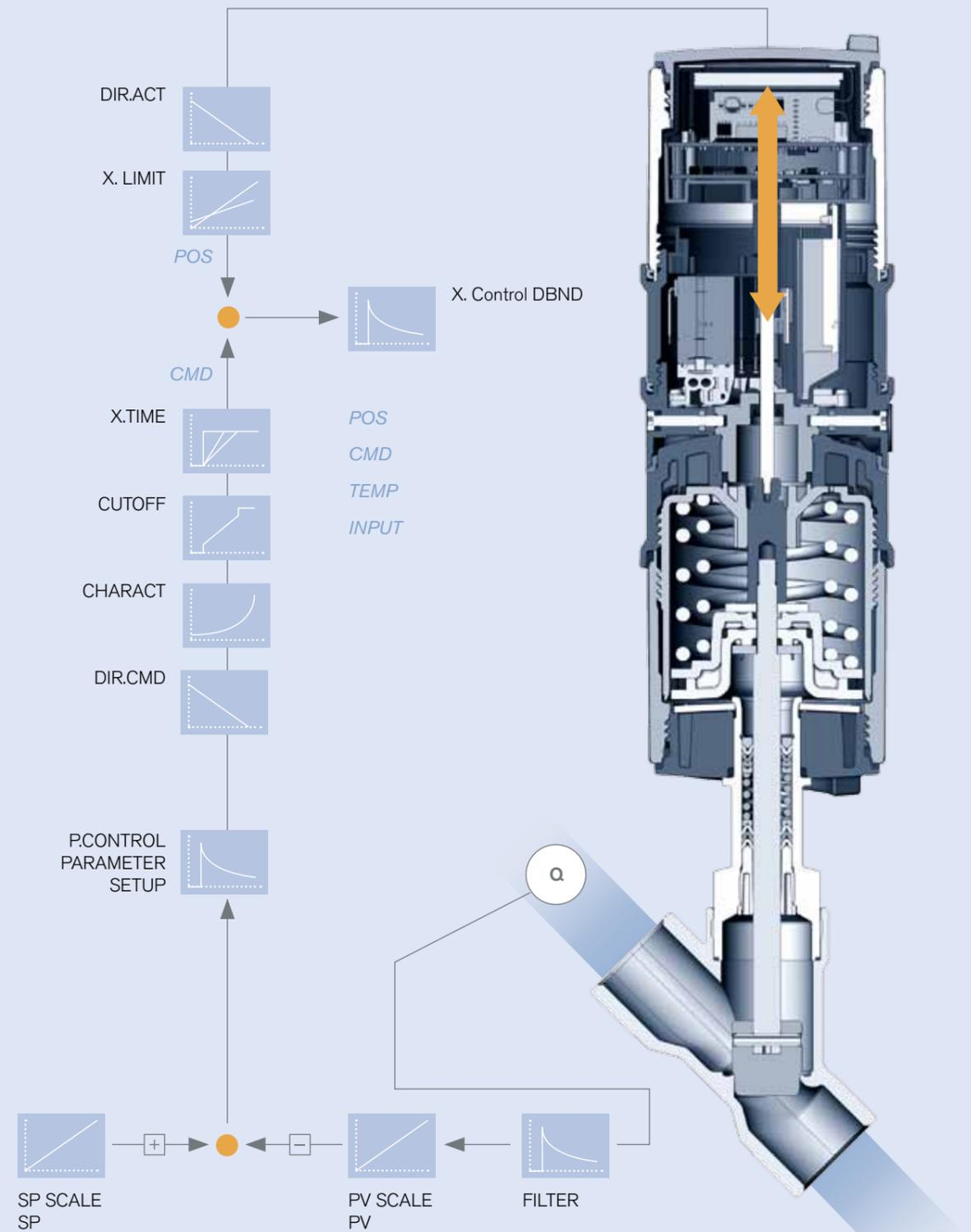



## Intuitive Intelligence Inside Valves

### Complete and adaptable to individual needs

The innovative positioner and controller range offers a complete automation concept for integration into the most up-to-date control systems. Designed for tough and agile process environments the devices design is particularly suited to the specific requirements of users in the food, cosmetic, beverage and pharmaceutical industries in terms of size, shape and cleanability, footprint and access code security.

### Configuration and Sizing Software Tools

Uncomplicated and updated configuration tools are available online backed up with our local well trained and friendly technical support. We also optimize our commercial offers by including information to simplify your decisions such as drawing support for complex piping arrangements.

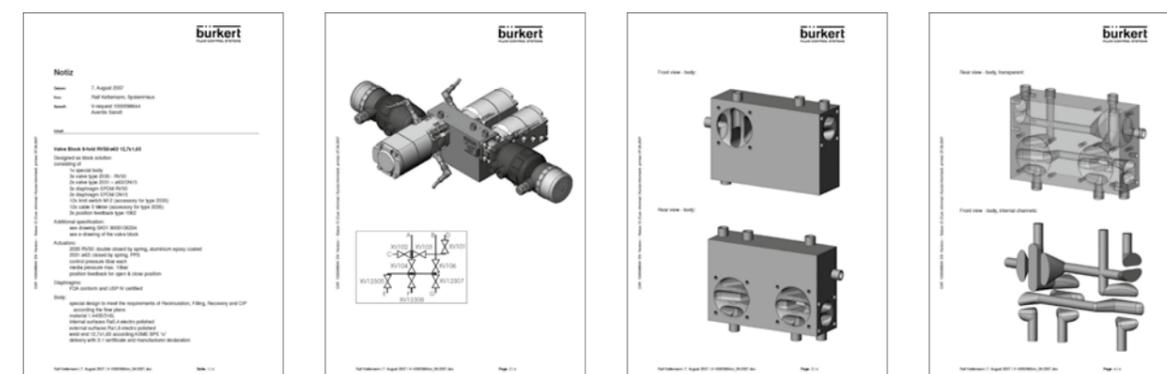

Typical total process valve solution offer

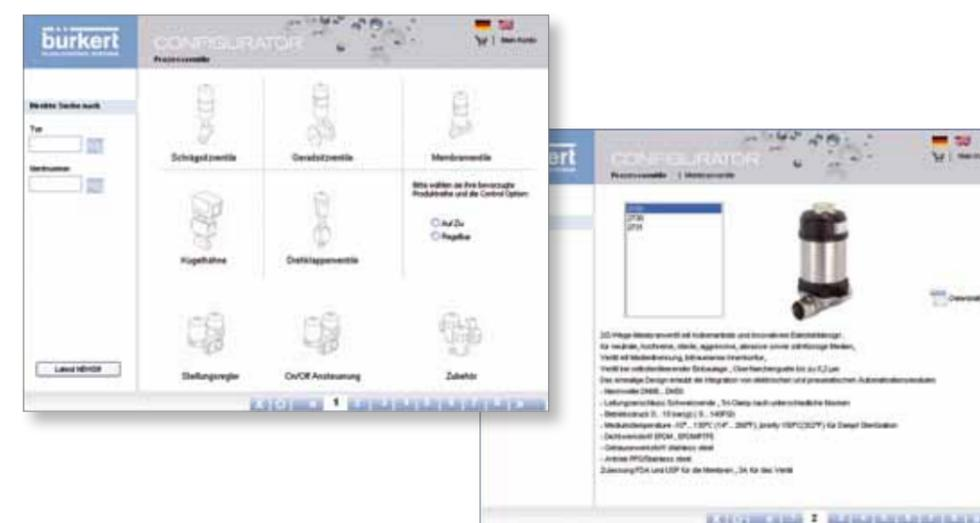

With considerably less investment in planning, assembly and costly wiring ELEMENT makes your process life simpler.

## Intelligent Technology in the Field

### The status quo:

#### Application-specific standardization of systems

As a key technology in the automation sector, fieldbus technology now offers a range of standardized bus systems that have been specialized and optimized for specific industries or specific applications.

Opening up this intelligent technology with optimum efficiency for the customer is a welcome and sought-after challenge for our team of consultants who, owing to their pioneering experience, process the crucial knowledge for developing future-oriented solutions. And what would highly qualified engineers find more motivating than an unsolved problem?

The fact that Bürkert has the "tickets" for the future-oriented fieldbus technology worldwide makes the choice simple for our customers, but "difficult" for our experts who wish to be challenged by new tasks.

#### Catching the right bus

The "evolution" of network technology has essentially developed from the principle of centralization through to distributed intelligence. Of course, this also necessitates components that comply with all aspects of the new "command structure". Maximum availability and minimum possible downtimes are but two key aspects of more efficient, i. e. advanced, operation of a system or installation which is based on future-proof fieldbus technology. It is certainly worth considering opting for a technology leader who has been involved right from the very start and who can therefore provide the appropriate solution to an individual problem as an integrated system. With Bürkert, you are riding the bus to the future.

### Networking:

#### Information on the future of networking

Various user associations track the ongoing evolution of individual bus systems. Visiting the following websites will fill you in on the latest developments:

- AS-International Association  
[www.as-international.net](http://www.as-international.net)
- CANopen  
[www.can-cia.de](http://www.can-cia.de)
- DeviceNet  
[www.odva.org](http://www.odva.org)
- Ethernet  
[www.iaona-eu.com](http://www.iaona-eu.com)  
[www.ida-group.org](http://www.ida-group.org)  
[www.odva.org](http://www.odva.org)  
[www.profibus.com](http://www.profibus.com)
- FOUNDATION Fieldbus  
[www.fieldbus.org](http://www.fieldbus.org)
- HART Communication Foundation  
[www.hartcomm.org](http://www.hartcomm.org)
- INTERBUS Club  
[www.interbusclub.com](http://www.interbusclub.com)
- PROFIBUS International (OI)  
[www.profibus.com](http://www.profibus.com)



Ethernet



## Market Oriented Solutions

### Want more flexibility

Each level of our architecture can be adapted to provide real solutions. Our bodies can be manifolded together, our actuators can operate other types of valve and our control and communication structures can decentralize your intelligence and help you visualize what is happening in your plant or your machinery.

### Yoke mounted solutions

We have a long history of providing some of the leading control valve manufacturers with positioners they can rely on to make their process valves work more efficiently and communicate with the latest standards. All of the advantages of the ELEMENT software is available inside the latest side mount units.

### Sanitary solutions

Control heads, positioners and process controllers and actuators for sanitary valves for the brewing, beverage and dairy industries fit the environment perfectly. We can interface with your current solution or build a whole new system.

### Customized solutions

We can interface with many other sensor and valve technologies to produce plug and work systems for any control loop or array. We will listen with the intent of providing the correct solution in your daily application language.

### Quarter turn solutions

There are still many applications which require the use of a ball control valve. Here accuracy, repeatability and simple set up are important. Our new 8792 and 8793 are both designed to work right on top of your choice of ISO5211 actuator.



Type 8792 / 8937 fully functional positioner for adaption to yoke or quarter turn valves.



Type 8791 - remote, cabinet mounted positioner



Type 8791 - Positioner BASIC



### Yoke mount

Our 8793 fully equipped process controller can be mounted on any yoke. It accepts a large spectrum of signals from process sensors and can compare these to a given setpoint. This is true decentralized intelligence allowing you to control and visualize the process.



### Precision sanitary actuators and positioners

We have controlled a wide range of hygienic plug valves, weirless diaphragm valves and sanitary ball and butterfly valves.



### Systems with flexible software

We have developed market oriented solutions by having flexible control architectures which can meet industrial requirements quickly.



### Rack and pinion mount

Through the standard ISO connection it is simple to integrate all of our intelligence on any of your quarter turn drives.



## Approvals Behind our Success

Over the course of the years, individual directives and national standards have resulted in clear standards that have been implemented in national or international law by the legislature. These recognized regulations ensure that equipment items from different countries are compatible and that manufacturers adhere to a set of regulations regarding design and production.

These regulations relate to the following aspects:

- Protection against risks and dangers
- Interfaces between technical systems
- Testing and inspections of products
- Clear description of the content and the characteristics of products

Legal supervisory authorities require that system operators use only equipment which meets the necessary safety requirements pursuant to these regulations.

Bürkert has the largest number of valves which have been granted the corresponding global approvals.

### European approvals

The European approvals and CE mark must be considered in conjunction with one another. As products with CE marking comply with the specified safety regulations, these marked products must be accepted in all EU and EFTA states. A distinction is made between the regulated and unregulated area. The CE mark on Bürkert devices refers to

- Electromagnetic compatibility in the areas
- Low Voltage Directive with the following limits:
  - 75 – 1500 V for DC voltages
  - 50 – 1000 V for AC voltages
- Pressure Equipment Directive

In regulated areas, the requirement stipulates that an independent body must conduct an CE type examination:

- Pressure Equipment Directive
- Gas Appliances Directive
- ATEX Directive

In unregulated areas, it is the manufacturer's direct responsibility to attach the CE mark. In this case, a Declaration of Conformity may be required of the manufacturer, specifying the standards applied. Depending on the particular application, the following directives may apply to Bürkert:

- Low Voltage Directives
- Electromagnetic Compatibility Directive
- Vehicle Directives
- Medical Device Directives

### North American approvals

The American Occupational Safety and Health Administration (OSHA) drew up the OSHA Regulation. In Standard 29 CFR, the requirement for electrical installations or equipment stipulates that only installations or equipment which have been tested for the specified safety requirements by an NRTL (National Registered Test Laboratory) may be installed. The NRTLs specified include the following:

- Underwriters' Laboratories (UL) for UL-listed, UL-recognized, UL-classified
- Factory Mutual (FM)
- Canadian Standards Association (CSA)

The complete CSA approval, from the measurements to be carried out up to preparation of the documents can be conducted internally as we have achieved "Category Certification" status.

### Hazardous locations

Valves for ATEX Directives (formerly Explosion-Protection (EX) Directives) covers equipment, components and protection systems for use in hazardous areas. It also applies to safety facilities outside of hazardous areas if they are required for safe operation of equipment in the hazardous area with respect to the risk of explosion.

Details for all global directives can be found in our brochure Hazardous Locations.

### Hygienic approvals and norms

Many of our process valves are employed in hygienic processing areas which follow industry and governmental guidelines and regulations which include 3A certification, EHEDG guidelines and FDA compliance for both internal wetted materials or outside cleanable design. We have many years of experience which assure our clients that our equipment will fit their every requirement and back it up with the relevant traceable documentation.



## Added Value Systems

Bürkert has a unique perspective in the process control and instrumentation industry as we are the only single brand which combines a complete range of valves, instruments, pneumatic actuation, networking and controllers from a single source.

With our dedicated world-class engineers and our superlative manufacturing facilities we can deliver systems which meet your exact requirements.

Your reliable Bürkert sales consultant and our system engineers work in concert to ask the right questions and provide the right hardware. Transparent operations, up to date situation, review procedure, engineering change notices, portals through SAP and secure intranet are normal in our projects.

For a world class system experience, insist on Bürkert people to be part of your next project.



### 01 Connect

As a globally flexible, lean, focused and innovative company we are the partner of choice for fluid control systems in more than 35 countries. Whether you are in Stuttgart, Singapore, Chicago or Sydney, everywhere in the world, we are close to you and therefore know at first-hand about your specific tasks and problems.

Following our principle of "one face to the customer", you have a competent, reliable consultant by your side at all times, who listens to your needs and presents a solution in your daily application language ... crossing conventional boundaries and creating synergies between industries in pursuit of your ideal solution.

Systemhaus crews in Charlotte (USA), Suzhou (China), Dresden, Ingelfingen and Dortmund are continuously in innovation mode. They creatively engineer cost effective solutions to meet difficult process challenges for our customers.



### 02 Conceive & Innovate

Your project team starts working for you: from your reliable sales consultant, qualified industry specialists to dedicated system engineers – Bürkert puts the necessary experts together.

For the entire duration of the project they work together, combining their experience and clarifying all the requirements in close cooperation with you to come up with a feasible draft of your solution within the shortest timeframe.

CAD-created animations or simulations, combined with extended manufacturing, materials, tool design, construction and assembly knowledge enable us to provide a rough but firm production concept for your system at an early stage.



### 03 Plan & Specify

In Phase 3 the project is planned in detail. A specification sheet and refined solution concept are developed. This defines exactly what you expect from the system and what it must provide to ensure that all components meet your requirements.

At the end of this phase you are presented with a detailed product definition, a production specification and precise commercial conditions and agreements.

Structured project management based on open communication, effective coordination and thorough documentation ensures fast and reliable results.



### 04 Do & Check

Good communication, coordination and documentation at all project phases make sure that we are on the right track, developing the right solution, to allow us to quickly move on to prototyping.

Thanks to the latest technology, we are able to build a prototype made of metal or plastic or a functional model to test flow for example within 24 hours.

We provide you with samples; we perform tests and, of course, obtain all the necessary local and global approvals to make sure the system can go to production.

From here we work in concert with one of our production facilities in Ingelfingen, Gerabronn, Criesbach, Öhringen or Triembach according to their individual core manufacturing competencies.



### 05 Complete

Our work does not end with the perfect delivery of components and systems. We offer a comprehensive program to our global clients interlinking services ranging from maintenance and service contracts, operator training and integrated logistics.

Our customer service is available around the clock, offering support through internet, telephone or our qualified, experienced people at your site.

We aim to provide only the utmost in customer experience. Something you will tell your friends about.

# Bürkert – Close to You

## Germany

### Sales Center

*Ingelfingen*  
Bürkert GmbH & Co. KG  
Christian-Bürkert-Straße 13-17  
DE-74653 Ingelfingen  
Tel: +49 (0)7940/10-91 111  
Fax: +49 (0)7940/10-91 448  
E-mail: info@buerkert.de

### Sales Offices

*Berlin*  
Bürkert GmbH & Co. KG  
Paradiesstraße 206 b  
DE-12526 Berlin  
Tel: +49 (0)30/679717-0  
Fax: +49 (0)30/679717-66

### Hannover

Bürkert GmbH & Co. KG  
Rendsburger Straße 18  
DE-30659 Hannover  
Tel: +49 (0)511/90276-0  
Fax: +49 (0)511/90276-66

### Dortmund

Bürkert GmbH & Co. KG  
Holzener Straße 70  
DE-58708 Minden  
Tel: +49 (0)2373/9681-0  
Fax: +49 (0)2373/9681-50

### Frankfurt

Bürkert GmbH & Co. KG  
Am Flugplatz 27  
DE-63329 Egelsbach  
Tel: +49 (0)6103/9414-0  
Fax: +49 (0)6103/9414-66

### Stuttgart

Bürkert GmbH & Co. KG  
Ulmer Straße 4  
DE-70771 Leinfelden-Echterdingen  
Tel: +49 (0)711/45110-0  
Fax: +49 (0)711/45110-66

### München

Bürkert GmbH & Co. KG  
Elsenheimerstraße 47  
DE-80687 München  
Tel: +49 (0)89/829228-0  
Fax: +49 (0)89/829228-50

## North and South America

### Argentina

Bürkert-Contromatic Argentina S.A.  
Uruguay 2602, Centro Uruguay Norte,  
P.B. Oficina 1, (B1643EKP) Beccar,  
Pcia. de Buenos Aires, ARGENTINA  
Tel: +54 (0)11-5648-6350  
Fax: +54 (0)11-5648-6355  
E-mail: contacto.argentina@buerkert.com

### Brazil

Bürkert-Contromatic Brasil Ltda.  
Rua Américo Brasiliense, 2069  
Chacara Santo Antônio  
04715-005 São Paulo - SP BRAZIL  
Tel: +55 (0)11-2186 1155  
Fax: +55 (0)11-2186 1165  
E-mail: pedidos.brasil@buerkert.com

### Canada

Bürkert Contromatic Inc.  
5002 South Service Road  
Burlington, Ontario L7L 5Y7, CANADA  
Tel: +1 905-632 30 33  
Fax: +1 905-632 38 33  
E-mail: sales.ca@buerkert.com

### USA

BURKERT CONTROMATIC CORP.  
2915 Whitehall Park Drive, Suite 100  
Charlotte, NC 28273, USA  
Tel: +1 704-504 44 40  
Fax: +1 949-223 31 98  
E-mail: marketing-usa@buerkert.com

## Europe

### Austria

Bürkert-Contromatic G.m.b.H.  
Diefenbachgasse 1-3  
AT-1150 Wien  
Tel: +43 (0)1-894 13 33  
Fax: +43 (0)1-894 13 00  
E-mail: info@buerkert.at

### Belgium

Bürkert Contromatic NV  
Wijnegem Zone 1 "De Hoek"  
Bijkhoevelaan 3  
BE-2110 Wijnegem  
Tel: +32 (0)3-325 89 00  
Fax: +32 (0)3-325 61 61  
E-mail: BC-B@buerkert.com

### Czech Rep.

Bürkert-Contromatic G.m.b.H. organizacni slozka  
Krenova 35  
CZ-602 00 Brno  
Tel: +420 543-25 25 05  
Fax: +420 543-25 25 06  
E-mail: obchod@buerkert.cz

### Denmark

Bürkert-Contromatic A/S  
Hørkær 24  
DK-2730 Herlev  
Tel: +45 44-50 75 00  
Fax: +45 44-50 75 75  
E-mail: info.dk@buerkert.com

## Europe, continued

### Finland

Bürkert Oy  
Atomitie 5  
FI-00370 Helsinki  
Tel: +358 (0)207 412 550  
Fax: +358 (0)207 412 555  
E-mail: sales.fi@buerkert.com

### France

BURKERT CONTROMATIC SAS  
Rue du Giessen  
FR-67220 Triembach au Val  
Tel: +33 (0)388-58 91 11  
Fax: +33 (0)388-57 20 08  
E-mail: burkert.france@buerkert.com

### Italy

Bürkert Contromatic Italiana S.p.A.  
Centro Direzionale „Colombiolo“  
Via Roma, 74  
IT-20060 Cassina De' Pecchi (Mi)  
Tel: +39 02-959 071  
Fax: +39 02-959 07 251  
E-mail: info@buerkert.it

### Netherlands

Bürkert Contromatic BV  
Computerweg 9  
NL-3542 DP Utrecht  
Tel: +31 (0)346-58 10 10  
Fax: +31 (0)346-56 37 17  
E-mail: info@buerkert.nl

### Norway

Bürkert-Contromatic A/S  
Hvamstuppen 17  
NO-2013 Skjetten  
Tel: +47 63-84 44 10  
Fax: +47 63-84 44 55  
E-mail: info@buerkert.no

### Poland

Burkert-Contromatic GmbH Oddzial w Polsce  
Bernardynska street 14 a  
PL-02-904 Warszawa  
Tel: +48 (0)22-840 60 10  
Fax: +48 (0)22-840 60 11  
E-mail: buerkert@buerkert.pl

### Portugal

Tel: +351 212 898 275  
Fax: +351 212 898 276  
E-mail: portugal@buerkert.com

### Spain

Bürkert Contromatic S.A.  
Avda. Barcelona, 40  
ES-08970 Sant Joan Despi, Barcelona  
Tel: +34 93-477 79 80  
Fax: +34 93-477 79 81  
E-mail: spain@buerkert.com

### Sweden

Bürkert-Contromatic AB  
Kattsundsgatan 27  
SE-211 26 Malmö  
Tel: +46 (0)40-664 51 00  
Fax: +46 (0)40-664 51 01  
E-mail: info.se@buerkert.com

### Switzerland

Bürkert-Contromatic AG Schweiz  
Bösch 71  
CH-6331 Hünenberg ZG  
Tel: +41 (0)41-785 66 66  
Fax: +41 (0)41-785 66 33  
E-mail: info.ch@buerkert.com

## Europe, continued

### Turkey

Burkert Contromatic Akiskan Kontrol  
Sistemleri Ticaret A.S.  
1203/8 Sok. No2-E  
TR-Yenisehir, Izmir  
Tel: +90 (0)232-459 53 95  
Fax: +90 (0)232-459 76 94  
E-mail: burkert@superonline.com

### United Kingdom

Burkert Contromatic Limited  
Brimscombe Port Business Park  
Brimscombe, Stroud  
Glos, GL5 2QQ / UNITED KINGDOM  
Tel: +44 (0)1453-731 353  
Fax: +44 (0)1453-731 343  
E-mail: sales.uk@buerkert.com

## Africa

### South Africa

Bürkert Contromatic (Proprietary) Limited  
233 Albert Amon Road  
Millennium Business Park  
Meadowdale,  
Germiston  
(Postal: P.O. Box 26260, East Rand 1462)  
SOUTH AFRICA  
Tel: +27 (0)11-574 60 00  
Fax: +27 (0)11-454 14 77  
E-mail: sales.za@buerkert.com

## Asia Pacific

### Australia

BURKERT CONTROMATIC AUSTRALIA PTY.  
LIMITED  
15 Columbia Way, Norwest Business Park  
Baulkham Hills, NSW 2153, AUSTRALIA  
Tel: +61 2 8853 6353  
Fax: +61 2 8853 6363  
E-mail: sales.au@buerkert.com

### Victoria

BURKERT CONTROMATIC AUSTRALIA  
PTY. LIMITED  
Unit 11/26-30 Howleys Road  
Notting Hill Victoria 3168  
Tel: 1300 888 868  
Fax: 1300 888 076

### Queensland

BURKERT CONTROMATIC AUSTRALIA  
PTY. LIMITED  
Unit 4/43 Sandgate Road  
Albion Queensland 4010  
Tel: 1300 888 868  
Fax: 1300 888 076

### Western Australia

BURKERT CONTROMATIC AUSTRALIA  
PTY. LIMITED  
Unit 8, 1st Floor, 85 Reid Promenade  
Joondalup WA 6027  
Tel: 1300 888 868  
Fax: 1300 888 076

### South Australia

BURKERT CONTROMATIC AUSTRALIA  
PTY. LIMITED  
Innovation House, First Avenue  
Mawson Lakes SA 5095  
Tel: 1300 888 868  
Fax: 1300 888 076

## Asia Pacific, continued

### China

Burkert Contromatic (Suzhou), Co., Ltd.  
(System House) Unit A5, Suhong Square  
No. 81 Suhong West Road  
SIP Suzhou P.R. China, 215021  
Tel: +86 512 6265 8498  
Fax: +86 512 6265 9337

Burkert Contromatic (Shanghai), Co., Ltd.  
(logistic and warehouse for BC China)  
Floor 2, block 6, 166 Mingdong Road  
Pudong New District  
Shanghai 201209, P.R. CHINA  
Tel: +86 21-5863 9990  
Fax: +86 21-5863 9968  
E-mail: info.chn@buerkert.com

### Beijing

Burkert Contromatic (Shanghai), Co., Ltd.  
Room A 1708, Luowa Building, No.203  
Er Ou Lizezhongyuan, Wangjing,  
Chaoyang District  
Beijing P.R. China, 100102  
Tel: +86 10 6439 9783, 6439 9793  
Fax: +86 10 6439 9612

### Chengdu

Burkert Contromatic (Shanghai), Co., Ltd.  
B zone, 2nd floor,  
DongFangGuangYi office building  
LongTan city industrial zone, 2nd section,  
East 3rd ring Rd.  
Chengdu, China 610051  
Tel: +86 28 8425 1434, 8425 1435  
Fax: +86 28 8425 1560

### Guangzhou

Burkert Contromatic (Shanghai), Co., Ltd.  
Room 1502, Tower 4, Dong Jun Plaza  
828 - 836 Dong Feng Road East  
Guangzhou P.R. China, 510080  
Tel: +86 20 8769 8379, 8767 8703  
Fax: +86 20 87671131

### Shanghai

Burkert Contromatic (Shanghai), Co., Ltd.  
Room 501/502 Xin Gai Nian Mansion  
No.39 Wu Zhong Road  
Shanghai P.R. China, 200233  
Tel: +86 21 6486 5110  
Fax: +86 21 6487 4815

### Suzhou

Burkert Contromatic (Shanghai), Co., Ltd.  
Unit 11-12, 5th Floor, Block A  
No.5 Xinghan Street  
SIP Suzhou P.R. China, 215021  
Tel: +86-512-6265 9881  
Fax: +86-512-6265 9882

### Hong Kong

Burkert Contromatic (China/HK) Limited  
Unit K, 9/Floor, Kwai Shun Industrial Centre  
No. 51-63 Container Port Road  
Kwai Chung, N.T., HONG KONG  
Tel: +852 2480 1202  
Fax: +852 2418 1945  
E-mail: info.hkg@buerkert.com

### India

Burkert Contromatic PVT Ltd  
Apex Towers, 1st Floor, No. 54 II Main Rd  
RA Puram  
Chennai 600 028, INDIA  
Tel: +91 (0)44-4230 3456  
Fax: +91 (0)44-4230 3232  
E-mail: sales.in@buerkert.com

### Japan

Burkert Ltd.  
Imasu moto asakusa-building  
4-9-14 Moto Asakusa, Taito-ku  
Tokyo 111-0041, JAPAN  
Tel: +81 (0)3-5827-0066  
Fax: +81 (0)3-5827-0067  
E-mail: info.jp@buerkert.com

### Osaka

Burkert Ltd.  
2-8-8-1103 Higashi Nakajima,  
Higashi-Yodogawa-ku  
Osaka 533-0033, JAPAN  
Tel: +81 (0)6-6320-0880  
Fax: +81 (0)6-6320-0881

### Korea

Burkert Contromatic Korea Co., Ltd.  
C-401, Micro Office Bldg. 554-2  
Gasam-Dong, Keumcheon-Gu  
Seoul 153-803, KOREA  
Tel: +82 (0)2-3462 5592  
Fax: +82 (0)2-3462 5594  
E-mail: info.kor@buerkert.com

### Malaysia

BURKERT CONTROMATIC SINGAPORE PTE LTD  
2F-1, Tingkat Kenari 6  
Sungai Ara  
11960 Penang, MALAYSIA  
Tel: +60 (0)4-643 5008  
Fax: +60 (0)4-643 7010  
E-mail: info.sin@buerkert.com

### New Zealand

BURKERT CONTROMATIC NEW ZEALAND  
LIMITED  
44 Rennie Drive  
Airport Oaks, Auckland 2022  
NEW ZEALAND  
Tel: +64 (0)9-256 77 37  
Fax: +64 (0)9-256 77 47  
E-mail: sales.nz@buerkert.com

### Philippines

BURKERT CONTROMATIC PHILIPPINES, INC.  
8467 West Service Road, Km. 14, Sunvalley  
South Superhighway, Parañaque City, 1700  
Metro Manila, PHILIPPINES  
Tel: +63 (0)2-7766071 / 7764384  
Fax: +63 (0)2-7764382  
E-mail: info.rp@buerkert.com

### Singapore

BURKERT CONTROMATIC SINGAPORE PTE LTD  
51 Ubi Avenue 1, #03-14  
Paya Ubi Industrial Park  
Singapore 408933, SINGAPORE  
Tel: +65 6844 2233  
Fax: +65 6844 3532  
E-mail: info.sin@buerkert.com

### Taiwan

Burkert Contromatic Taiwan Ltd.  
9 F, No. 32, Chenggong Road, Sec. 1,  
Nangang District  
Taipei  
TAIWAN 115, R.O.C.  
Tel: +886 (0)2-2653 7868  
Fax: +886 (0)2-2653 7968  
E-mail: info.rc@buerkert.com



**bürkert**  
FLUID CONTROL SYSTEMS

**Bürkert Fluid Control Systems**

Christian-Bürkert-Straße 13-17  
74653 Ingelfingen  
Germany

Tel. +49 (0) 7940/10-0  
Fax +49 (0) 7940/10-91 204

info@burkert.com  
www.burkert.com