

# Hygienic Processing



**Bürkert Fluid Control Systems**

Christian-Bürkert-Straße 13-17  
74653 Ingelfingen  
Germany

Tel. +49 (0) 7940/10-0  
Fax +49 (0) 7940/10-204

info@burkert.com  
www.burkert.com

**bürkert**  
FLUID CONTROL SYSTEMS

## Content

- 5 \_\_\_\_\_ Company Profile
- 6 \_\_\_\_\_ Products and Systems
- 9 \_\_\_\_\_ Hygienic Processing
- 13 \_\_\_\_\_ Utilities: Steam and Heat Transfer
- 14 \_\_\_\_\_ Utilities: Clean-in-Place (CIP)
- 17 \_\_\_\_\_ Utilities: Water Treatment
- 20 \_\_\_\_\_ Process: Fermentation
- 23 \_\_\_\_\_ Process: Downstream Processing
- 24 \_\_\_\_\_ Process: Batching and Mixing
- 27 \_\_\_\_\_ Process: Filling Control
- 30 \_\_\_\_\_ Contacts at Bürkert



## Hygienic Processing.

Hygienic Processing is a customer-oriented concept to combine the physical attributes of the application environments from your world. In this overview you will find a virtual factory to examine some of our core process competences. We believe we have intimate knowledge and significant insight into the application environments, which traverse a spectrum of processing industries from pharmaceutical, nutraceutical, cosmetic, brewery, beverage, dairy, juice production, confectionary, and petfood.

We intend to collaborate with you in the real physics of batching, cleaning and sterilizing, water producing and distributing, filling, heating, cooling, separating, fermenting, distilling, or evaporating, where we can share our experience in complete control loops for flow, conductivity, pH, temperature, pressure, and level. We can help you determine the most effective communications architecture to help you really see what is happening in your plant from the control room or the board room.

Everyone in our organization is interested in listening to you with the aim of presenting only the most appropriate solution fluently in your daily application language. The inherent expertise available within the Bürkert organization exists to make your life simpler. Our versatile systems highlight our continuous customer-oriented innovation and are developed to simplify the hygienic world to save you time.

An otherwise unattainable synergy of hardworking valve elements, process actuation, sensors, and networked communication provides a true single source of remarkable attractive systems, peace of mind, process safety, and joy of use.

In the world of hygiene where compactness, smart communication, plant footprint, wash-down, dead legs, cross-contamination, and validation are everyday concerns, we provide process efficiency and higher yields by offering you unlimited process modularity.

## Welcome to the Fascinating World of Fluid Control Systems.

Measurement and control: When it comes to working with fluids and gases, we are at your side—as a manufacturer of sophisticated products, as a problem-solver with an eye for the big picture, and as a partner offering you reliable advice. Ever since we started in 1946, we have developed into one of the world's leading suppliers of Fluid Control Systems. But at the same time we have kept our status as a family-run business with a foundation of strong basic values to highlight the way we think and act.

### What we build on: Experience

We bring together over 60 years of applied knowledge, theoretical expertise and all-round experience in the field of Fluid Control Systems. We at Bürkert have always taken care to ensure that the insights gained in working on innumerable products and projects are passed on, not only among our over 2,000 employees in various locations and divisions but also from one Bürkert generation to the next. We focus all our curiosity, passion and commitment on one goal: to provide solutions that take your company that essential step forward.

### What sets us apart: Closeness

To engineer expert solutions with added value, you need to be close to your customers and their problems—as we are. For us at Bürkert, closeness means personal closeness: We listen to your every word and do everything in our power to devise and implement the best solution for your needs. But closeness also applies in a technical sense: We know exactly what role our products play in your complex processes. And last but not least, we understand closeness in a geographical sense: Our global presence with over 35 branches and seven production sites allows our customers to draw on technological innovations from all over the world.

### What drives us forward: Courage

We aim to surpass your expectations. To make it happen, one quality is vital: courage. The courage not just to look forward but to move forward, to challenge conventional wisdom, to do things differently, to tackle problems others think are impossible, to never give up when the going gets tough. We demonstrate this courage time and again. Our wealth of experience is the solid platform on which our courage is based. It allows us to turn courage into creativity, convert off-beat ideas into surprising innovations and put together individual components to create completely new systems that open up unexpected possibilities.

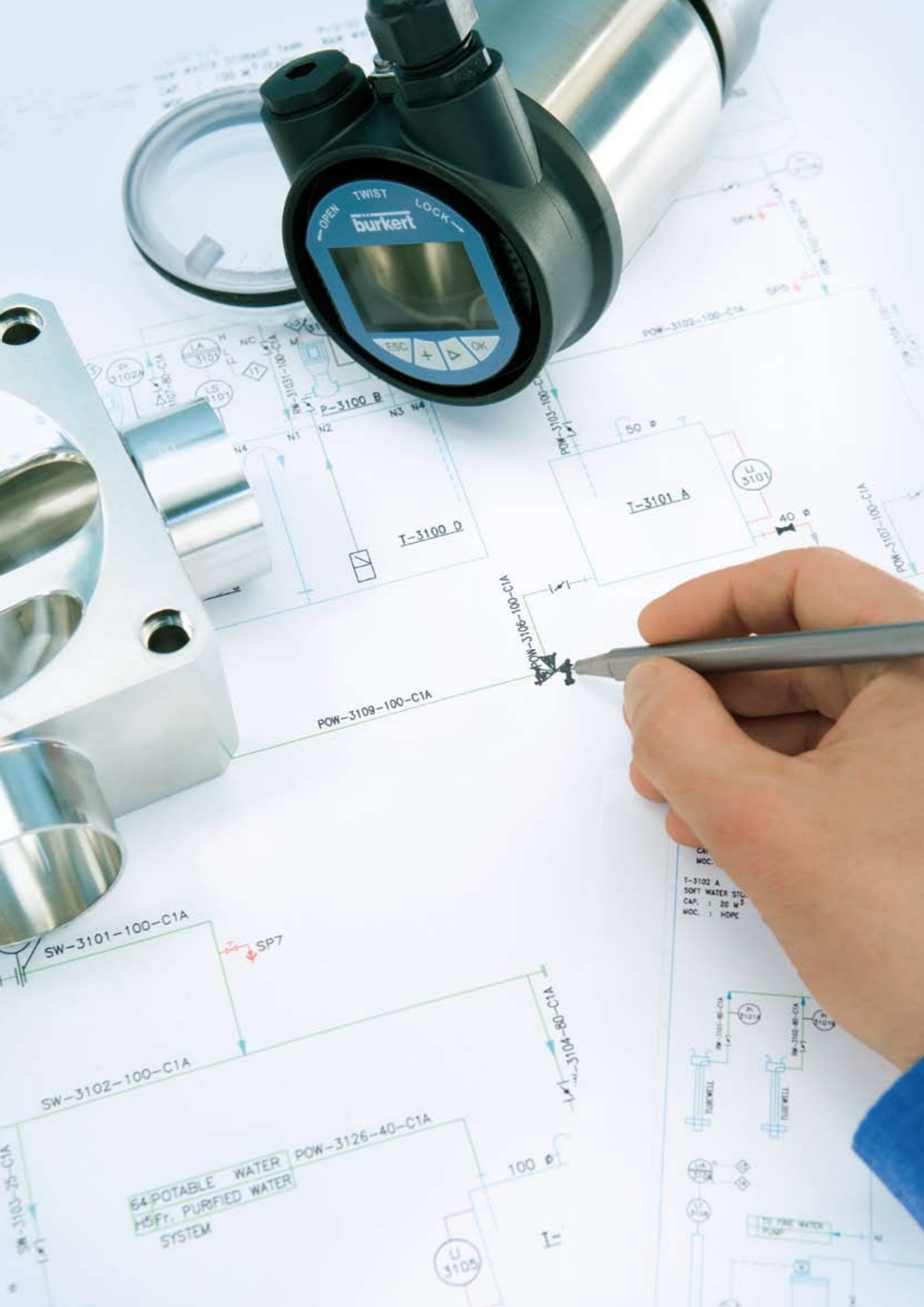



## Good from Every Angle: Our Products.

Fluids are fascinating media. And it is this very fascination with liquids and gases that drives us to develop ever-new devices that can handle them even better. We are one of the few suppliers on the market to cover the complete control loop. Our current product range extends from solenoid valves through process and analytical valves to pneumatic actuators and sensors.

To meet our customers' ever-increasing demands, the people at our four research and development centers constantly work on improving both our individual products and our range as a whole. Products that solve a particular problem perfectly, that offer a true value-added benefit over other products, and that meet specific industry requirements.

In the hygienic processing arena, we have worked continuously to be involved in the latest specifications, requirements, and special interest groups which push the industry towards higher standards and improved value for their customers. We believe we have done the work which allows you to have peace of mind. When you specify Bürkert you know you will receive real, traceable, consistent quality ... quickly.

## Innovative, Value-added Solutions Combine the Best of All Worlds.

You can see Bürkert as a supplier who simply provides you with good products. We are happy to fill that role—but what really makes us proud is when you see us as a partner who joins you in getting the job done—however complex. Even if the problem seems irresolvable, challenge us, put our courage to the test—it is the tough challenges that drive us, moving you and us forward.

We are at your side at all times with a seamless range of services, from consulting and engineering through installation, testing, and after-sales service. No matter if it is an individual component or a groundbreaking new system for the entire process of measurement and control.

We work with engineering consultants, integrators, contractors, original equipment manufacturers, and end users in a spectrum of industries from pet food to dairy to biotech. Expertise in CIP, WFI, batching and mixing, filling, distillation, bioreactors, steam and heat transfer, chromatography, and filtration ... in your application language. Speaking a common language eases communication and lays the foundation for your success.

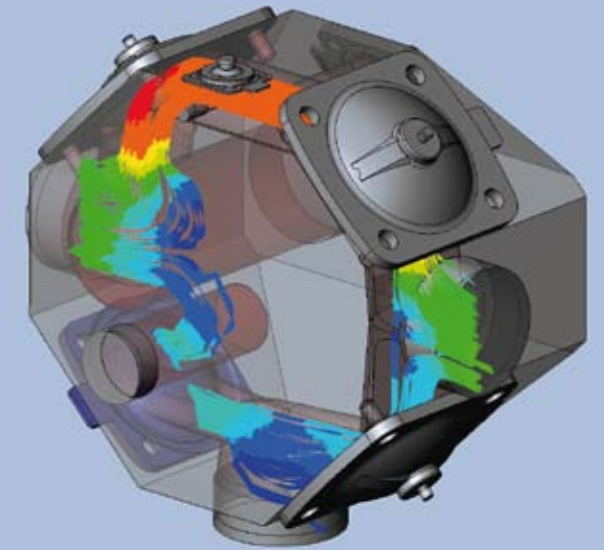
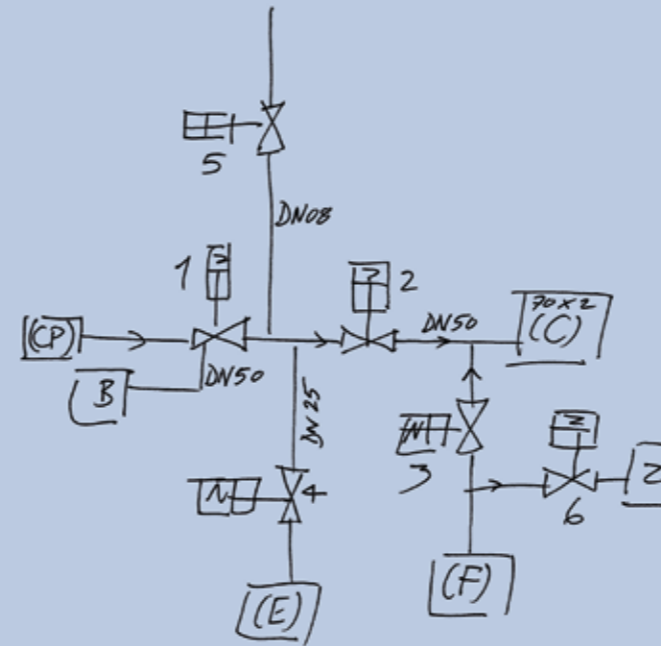

IDEAS & CONSULTING

SIMULATION & DEVELOPMENT

SYSTEM DEVELOPMENT

PROTOTYPE

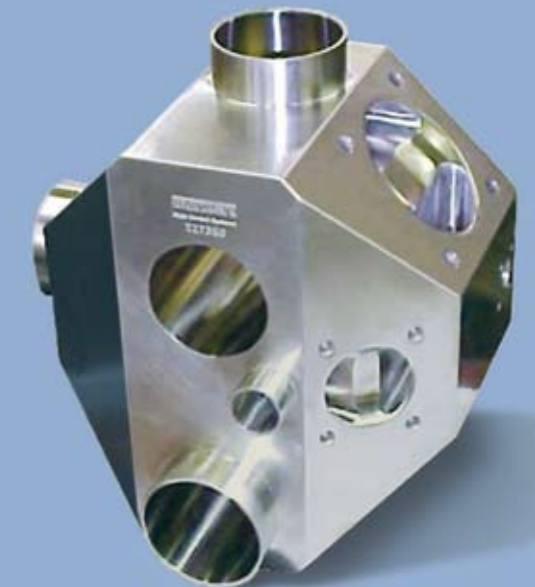



## We Help Your Ideas Flow.

In hygienic processing industries, measuring and controlling the flow of liquids and gases demands superior instrument performance and networkability.

Standard connectivity with modular, decentralized monitoring, intelligence, and diagnostics are the platform for flow control networks which provide reliable productivity data from your plant level flow network.

Fluids like ultra-pure water through to those with extreme viscosities, high solid concentrations and low conductivity, and clean or sterile manufacturing application environments present a wide range of flow challenges that we understand.

Components are designed according to global norms and standards for your critical food, cosmetic, beverage, or drug manufacturing processes.

Proven reliability, superior accuracy, and virtually maintenance-free service ensure Bürkert's systems deliver unsurpassed total performance in the form of complete flow control loop systems.

*Deploy control when and where you want it. We fit your control strategy.*



8644 process control center



1066 control top for remote control and feedback of process valves



8644 AirLINE process control center



# EXPERIENCE

There are things which are not inherently yours. You have to gather them bit by bit, you receive them from others, and you constantly have to acquire them anew. That is what makes them so valuable. Experience is one of those things. For instance, because of our many years of experience with hygienic processes and workflows, we can provide our extensive services to you—from consulting, development, and installation to testing and after-sales service. Whether individual product solutions or a pioneering new system for the entire measurement and control process: Benefit from our experience!



## Hot Ideas for Precise Control.

Bürkert provides cutting-edge solutions for heat transfer applications in your world.

From pasteurizer control to simple tempering of water, autoclaving of canned food to sterilization of dental equipment, our experience is steam. Your use of steam as a heat transfer media, a cleaning agent, or as a crucial sterile ingredient can be regulated precisely with Bürkert systems and solutions.

Through constant innovation our technology is designed to work with your steam in your hygienic environment.

Experience and knowledge acquired over many years means our systems are deployed globally. Our local engineering teams can take your process layout ideas and help you turn them into reality.

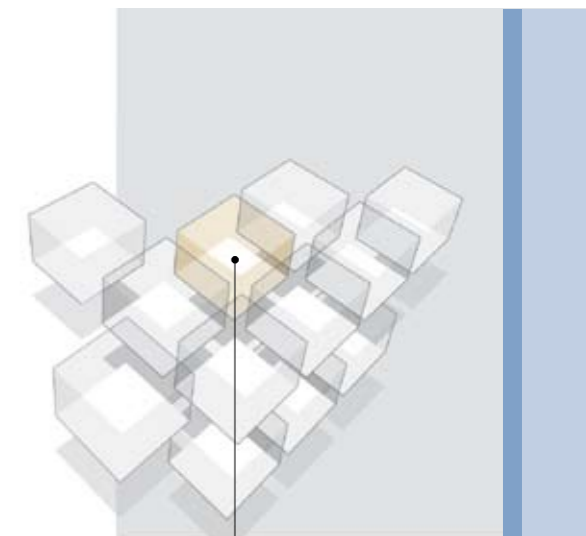

*Steam is an essential ingredient.*

*Hardworking valves are just the beginning.*



*On-off and continuous steam valves*



*8400 temperature transmitter*



*1067 valve-mounted PID process controller*

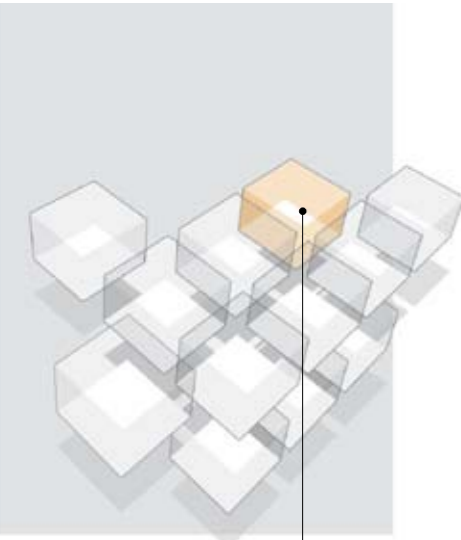

*CIP and SIP keep your customers safe.*

## Safe in Bürkert's Hands.

Your customers place trust in your product and safety is related to your brand.

Each stage of your CIP/SIP regime can be controlled and safely documented. Our stable and rugged components are designed for the harsh shifts from acid to base, and for the demands of washdown.

Our components and system solutions bring peace of mind. Your pH, conductivity, pressure and flow are all important to your consumers.

Reliability in switching from water to clean steam and from chemical to surfactant is standard in a range of valves which are designed for this purpose.

All of the CIP parameters are safe in Bürkert's hands allowing you to make your product with confidence.

---

*From make-up loop control to design of cleanable components, we are with you.*



*8226 inductive conductivity transmitter for CIP systems*



*3237 sanitary divert valve*



*8644 AirLINE process control center*







## Water—Your Most Valuable Ingredient.

In many industries water is known as the most important ingredient. Water quality is therefore often essential to the success of the product. Whether it affects the taste of beer or the sterility of an injectable saline solution, traceability and certification of water quality is standard procedure. We take the risk out of water production, distribution, and use.

Bürkert is involved in the complete water supply chain from ground-water treatment and incoming water supply processing to your most stringent requirements, inline verification, and final decontamination, treatment, and/or neutralization.

In the production of de-mineralized water, purified water, and water for injection(s) Bürkert's technology and expertise are employed with confidence.

---

*Our experience in water is evident: pH, conductivity, flow, pressure and level are under control.*

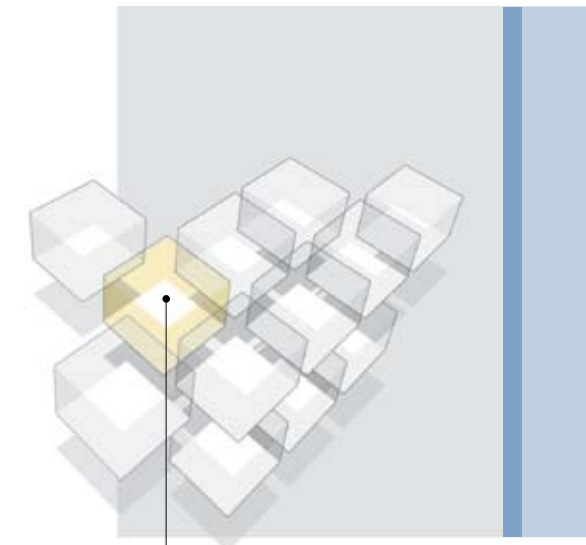

*Clean water is central to life and to your factory.*



*2030 chemical and water valves*



*Multi-channel controller for water treatment systems*



*8025 flow transmitter*



# COURAGE

Those who only work toward optimizing things that already exist will eventually reach the limits—technically, financially, or personally. In order to overcome these limits, courage is needed: The courage to be different and trust one's own ideas; the courage to venture into the unknown, searching for new ways to develop products that have never existed before. We have this courage. By pooling and utilizing our competencies across all sectors, you benefit from our cumulative knowledge of hygienic processes—whether it is in pharmaceuticals, the food industry, or the cosmetic industry.

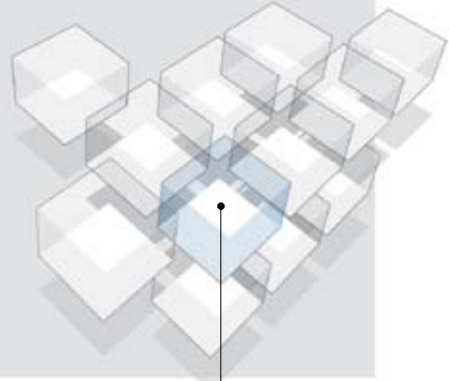

*Fermentation is the beginning of many products.*

## A Culture of Decentralized Networked Control.

Since prehistoric times humans have been taking control of the fermentation process. From Pasteur to Buchner to the Carlsberg scientists, the conversion of juice into wine, grains into beer, milk to yogurt, carbohydrates into carbon dioxide to raise bread, and sugars in vegetables into preservative organic acids. Today, fermentation provides a diversity of flavors, aromas, and textures in food substrates. It preserves, enriches, and detoxifies and produces important nutrients and drugs.

We have many years of experience in this area and our knowledge of the process provides our clients with confidence. Process safety is evident in our components for fermentor gas control, pH and pressure monitoring, and modular fieldbus solutions which are used to join individual reactors into coordinated processes.

---

*Fermenting requires control of both liquids and gases, temperature and pressure.*



*8645 FreeLINE control center for challenging environments*



*Mass flow controllers and meters for fermentor gas control*



*Diaphragm valve mounted with PID process controller*





## Downstream Processing.

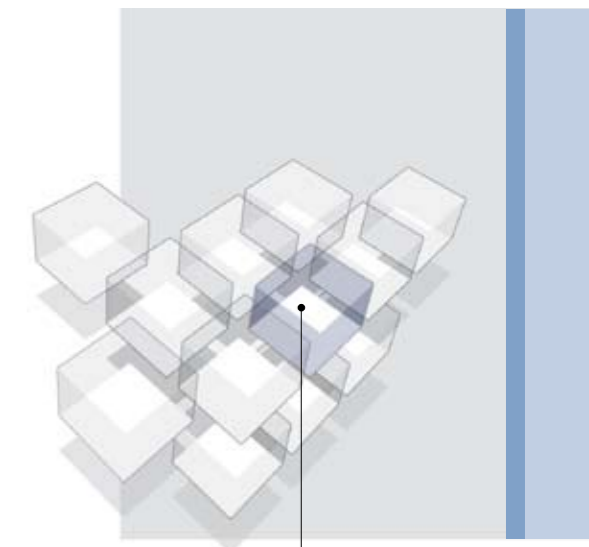

From filtration of beer to separation and identification of active drug ingredients, our unlimited modularity saves you valuable plant space and offers you peace of mind from dead legs and cross-contamination. Less welding means less validation, and our patented designs provide faster crossover times, higher process efficiencies, and higher yields.

Our unique Robolux multiway/multiport valves are compact and smart and our instrumentation for pressure, level, conductivity, and pH is easy to commission. Communication inside the skid may be made with AS-Interface and between skids with your preferred fieldbus.

*Filtration, separation and chromatography make up downstream processing.*

*Preparation for separation requires precise and flexible systems.*



*Multiport solutions for chromatography and filtration equipment*



*pH and conductivity sensors and transmitters for hygienic processes*



*8650 AirLINE Ex process control center for solvent areas*

## Recipe for Success.

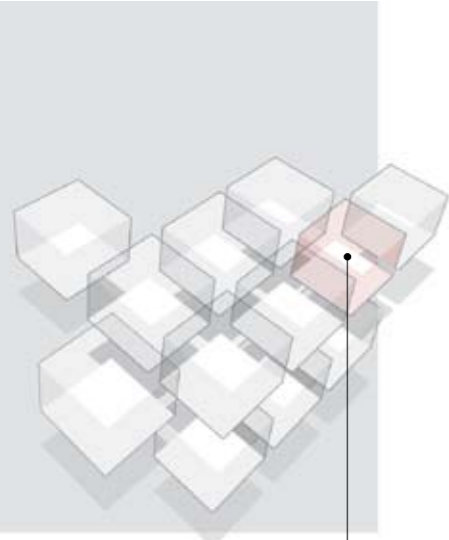

*The ability to mix and batch lets your customers enjoy your products.*

Precision, reliability, repeatability, and flexibility are the cornerstones of batching and mixing.

From simple components to dose chemicals and specific valves for yogurt filling to fully tested and approved systems for bread ingredients or pasta sauce.

We have batched and mixed primary active drug ingredients worth thousands of euros per gram, cookie mix, shampoo fragrances, cocoa butter ingredients, liquid flour, and syrups with whole fruit pieces.

Only the right ingredients count for the right taste and texture. Bürkert systems have brought peace of mind to thousands of customers by ensuring just the right mix.

---

*The right components plus the right experience makes systems future integrated.*



8035 versatile and simple to use batch controller



8311 pressure transmitter



8644 AirLINE process control center





## Refreshing Solutions.

Your production lines rely on the speed of your filling lines. Whether you fill 200 barrels per day or 20,000 packs per hour, our unique solutions help you exceed your targets.

Whether you are filling portion packages, cartons, briks, bags, or kegs, we are part of the solution for long, high volume production runs at lower operating costs. We help you to reach higher productivity and greater space efficiency in high-speed filling machines and we solve sticky problems at the plant level. Our products have proven themselves with superior cycle life, sterility, accuracy, and repeatability in plants around the world. Our support and experience is ready and willing. Whether your goal is cost-driven innovation for a new machine, getting the whole fruit into a yogurt container, or boosting production on your filling floor we are here to help.

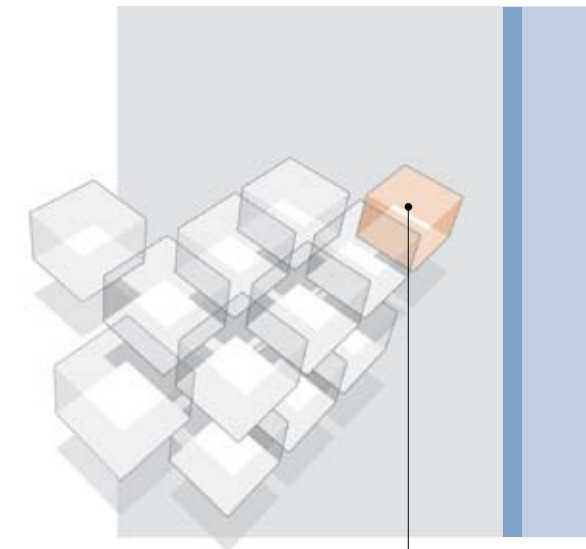

*Bürkert offers many standard and customized solutions for filling.*

*Filling industries demand reliable, fast, and accurate solutions.*



8055 high frequency mass flow batch controller



Range of standard and custom valves for accurate and reliable filling



8644 AirLINE process control center



## CLOSENESS

There are things we simply take for granted. Only when they are gone, do we realize how important these things really were. This applies in particular to closeness. Without closeness, it is very difficult to build relationships and a good understanding of one another. As an established medium-sized company, we know that. And that is why we are always there for you. Working with you, we develop the best possible solutions for your projects in the area of hygienic processes. Our global presence in 35 locations enables us to press ahead with technical innovations for our customers around the world.

